



**TOWN OF NIVERVILLE  
STANDARDS FOR DESIGN AND  
CONSTRUCTION OF  
PUBLIC WORKS**

**Project No: 191-00330-00**

**March 2019**

**May 30, 2019**

**February 2020**

**March 2021**



# TABLE OF CONTENTS

Page No.

<b>1.0</b>	<b>GENERAL</b> .....	<b>1</b>
1.1	APPLICABLE SPECIFICATIONS .....	1
<b>2.0</b>	<b>WATERWORKS</b> .....	<b>2</b>
2.1	APPROVED MATERIALS FOR WATER INSTALLATIONS.....	2
2.2	DESIGN AND CONSTRUCTION .....	4
	DRAWING G01 – TYPICAL WATER AND SEWER SERVICES LAYOUT .....	8
	DRAWING G02 – TYPICAL WATER AND SEWER SERVICES PROFILE VIEW.....	9
	DRAWING G03 – TYPICAL RESIDENTIAL WATER METER INSTALLATION .....	10
<b>3.0</b>	<b>WASTEWATER SEWERS</b> .....	<b>11</b>
3.1	GENERAL.....	11
3.2	PRODUCTS .....	13
3.3	EXECUTION.....	14
<b>4.0</b>	<b>LOW PRESSURE SEWERS</b> .....	<b>20</b>
4.1	MATERIALS .....	20
4.2	DESIGN AND CONSTRUCTION .....	21
<b>5.0</b>	<b>DRAINAGE CRITERIA</b> .....	<b>23</b>
5.1	APPROVED MATERIALS FOR DRAINAGE INSTALLATIONS .....	23
	DRAWING G04 – TYPICAL CULVERT DETAIL.....	24
	DRAWING G05 – TYPICAL ROADSIDE CATCH BASIN DETAIL .....	27
	DRAWING G06– TYPICAL ROAD SUB DRAIN DETAIL .....	28
5.2	DESIGN CRITERIA.....	29
<b>6.0</b>	<b>ROADWAYS</b> .....	<b>31</b>
6.1	GENERAL.....	31
6.2	PAVEMENT DESIGN CRITERIA .....	31
6.3	SUBGRADE .....	32
6.4	PAVEMENT SECTIONS .....	32
6.5	GEOTEXTILE FABRIC.....	33
	DRAWING G07 – TYPICAL ROAD CROSS SECTION.....	34
6.6	SURFACE.....	35
6.7	DRIVEWAYS .....	35
6.8	CUL-DE-SAC .....	36
6.9	GRAVEL ROAD GRADE.....	36
<b>7.0</b>	<b>SIDEWALKS</b> .....	<b>37</b>
7.1	DESIGN .....	37
	DRAWING G08 – TYPICAL DETAILS – LANES, SIDEWALKS, CONCRETE SWALES.....	38

<b>8.0</b>	<b>OTHER UTILITIES .....</b>	<b>39</b>
8.1	HYDRO AND TELEPHONE .....	39
8.2	ROAD SIGNS .....	39
<b>9.0</b>	<b>BOULEVARD AND LOT GRADING .....</b>	<b>40</b>
9.1	BOULEVARDS .....	40
9.2	LOTS.....	40
	DRAWING G09 – LOT GRADING CRITERIA.....	41
<b>10.0</b>	<b>PARKS</b>	<b>41</b>
10.1	GREENSPACE / PUBLIC RESERVE .....	42
<b>11.0</b>	<b>LANDSCAPING.....</b>	<b>42</b>
11.1	GENERAL.....	42
11.2	REQUIREMENTS .....	42
11.3	LANDSCAPING PLAN .....	42
11.4	LANDSCAPING DETAILS .....	43
11.5	PARKING .....	44
<b>12.0</b>	<b>CONCRETE .....</b>	<b>45</b>
<b>13.0</b>	<b>SEWAGE PUMPING STATIONS .....</b>	<b>46</b>
13.1	MATERIALS .....	46
13.2	DESIGN AND CONSTRUCTION .....	47
<b>14.0</b>	<b>QUALITY ASSURANCE.....</b>	<b>48</b>
14.1	INSTALLATION .....	48
14.2	TESTING .....	48
14.3	RESTORATION AND CLEAN-UP .....	48
14.4	TOPSOIL AND SEEDING .....	49
<b>15.0</b>	<b>PLANS.....</b>	<b>50</b>
15.1	PRELIMINARY DOCUMENTS .....	50
15.2	AS-CONSTRUCTED PLANS .....	50
15.3	WARRANTY PERIOD.....	50

## 1.0 GENERAL

### 1.1 Applicable Specifications

- (a) The specifications from City of Winnipeg, Manitoba Water Services Board and Manitoba Infrastructure are superseded by the standards noted in this document. Should a standard not be available, the City of Winnipeg, Manitoba Water Services Board and Manitoba Infrastructure standards should be followed and shall take precedence in the order as listed.
- (b) The City of Winnipeg Standard Construction Specifications, latest edition. These specifications are available on line at [www.winnipeg.ca/matmgt/spec/default.stm](http://www.winnipeg.ca/matmgt/spec/default.stm).
- (c) Manitoba Water Services Board (MWSB) Standard Construction specifications, latest edition is available on line at [www.mbwaterservicesboard.ca/standard-construction-specs.html](http://www.mbwaterservicesboard.ca/standard-construction-specs.html).

Note that the MWSB does not provide financial or technical assistance for projects that are not directly under their jurisdiction.

- (d) Manitoba Infrastructure (MI), latest edition. These specifications are available on line at <http://www.gov.mb.ca/mit/contracts/manual.html>.

## 2.0 WATERWORKS

### 2.1 Approved Materials for Water Installations

#### (a) General

The Town of Niverville (the Town) has designed a water treatment facility that meets and/or exceeds current Provincial requirements/standards. All new subdivisions and infill developments require connection to the Town's potable water system.

All materials shall conform to the relevant Standard Approval Listings of the Manitoba Water Services Board Standard Construction Specifications, most recent edition, with any exceptions being specifically outlined herein.

#### (b) Watermain Pipe

Watermain shall be either:

- PVC C900 Class 150 (AWWA C900 or C905)
- HDPE DR 17 PE 4710
- Any other types shall require approval from the Town

#### (c) Fittings

PVC fittings of similar type as pipe may be used on C900 PVC pipe (injection moulded or fabricated and FRP reinforced) C900 fittings with C900 pipe. Acceptable models shall be Ipex – Blue Brute, or Royal Pipe – Royal Seal.

#### (d) Valves

Gate valves shall conform to AWWA C509/C515, UL, FM, NSF 61 for resilient seat type with O-ring stem seals, non-rising spindle, left hand opening, with suitable pipe connections for IPS or D.I. OD. (Mueller, resilient wedge gate valve series A2360, or Clow/Kennedy resilient wedge gate valve series F6100 or approved equal).

#### (e) Valve Boxes

Gate valve boxes shall be telescoping type adjustable for bury depth. The upper section shall be ductile iron with a hinged cover with the mark "W" cast in. The lower section shall be PVC (DR 18 type). Each box shall have an extension spindle with a stone disc and 2 inch (50 mm) operating nut no more than 1.0 foot (0.3 m) below proposed ground level.

(f) Hydrants

Hydrants shall be AWWA C502 type, with dry top bonnet, compression type main valve no less than 5 inch (125 mm) diameter, left hand opening, for off line service with a six inch (150 mm) push-on or flanged joint suitable for PVC C900 or HDPE pipe, bronze-to-bronze seat ring, non-draining barrel no less than 7 inches (175 mm) in diameter, two hose and one pumper nozzle, all with caps and chains, Western Canadian/Manitoba Standard operating nuts and cap threads, a "break-away" ground line flange, and flat surfaces on the bottom and back of the boot. Hydrants shall be originally painted "Chinese Red" with black caps, no re-painted hydrants will be accepted. **Orange polyethylene hydrant markers as per City Winnipeg detail AP-005 shall be supplied and installed by the contractor at the time of hydrant installation.** Acceptable models shall be Clow M-67 Heritage Brigadier or Mueller Super Centurion. The Town of Niverville's Chief Administrative Office (CAO) or Designated Officer will confirm in writing which model shall be used in each location.

(g) Service Pipe

Community water service pipe shall be:

- HDPE Series 160 DR13.5 (CTS).
- Cross linked polyethylene ("Municipex")

(h) Corporation Stops

Corporation stops shall be bronze, ball-type, with standard tapered threaded inlet suitable for direct tap PVC C900 or HDPE DR 17 watermains, with a compression type outlet. Acceptable model shall be Mueller H15008, or approved equal.

(i) Curb Stops

Curb stops shall be bronze, ball-type, non-draining, with compression type joints. Acceptable model shall be Mueller H15209, or approved equal.

(j) Curb Boxes

Curb boxes shall be PVC Schedule 40 (CSA B137.3) 6.5 feet to 9 feet (2 to 3 m) depth, with a ribbed lid, with the word "water" cast in, five-sided nut (7/8 inches or 22 mm flat-to-point), 5/8 inch (16 mm) stainless steel rod, polymer plastic boot to fit curb stops, and a brass cotter pin centred on the yoke (WDVB or approved equal). Top of rod no more than 1 foot (0.3 m) below proposed ground elevations.

(k) Couplings (mains)

Couplings for PVC pipe shall be AWWA C907 – injection moulded PVC couplings. Acceptable model shall be IpeX – Blue Brute or approved equal.

Couplings for other material types or couplings for connections between varying pipe material types shall be on the MWSB approved product list and approved by the manufacturer for that specific application.

Use of electrofusion couplings for HDPE pipe shall be minimized and used only where approved by the Town. Locations of electrofusion couplings used shall be provided on completed record drawings.

(l) Connection Saddles

Saddles to be double strap or wide band type, all stainless steel, or all bronze wide body with all metal parts to be stainless steel 304/316 or ASTM – B62 bronze, minimum bolt size 10mm diameter. Acceptable models shall be Mueller or Ford, Romac 202BS, or approved equal.

(m) Main Line Tapping Sleeves

Tapping sleeves shall be all stainless-steel nuts, bolts, and washers. Acceptable models shall be Mueller – H304, Ford – Fast, Romac SST, or approved equal.

## 2.2 Design and Construction

(a) General

All design and construction shall conform generally to the Standard Specifications of the City of Winnipeg, with any exceptions being specifically outlined herein.

Installation of all underground utilities (gas, hydro, telephone, cable) under proposed or existing roadways shall be by trenchless methods. No open cut excavation of roadways shall be permitted.

(b) Bury Depth

All watermains shall be provided with a minimum cover over the crown of the pipe as follows; or as otherwise approved by the Town:

Urban Grade (Curb and Gutter Roads)

- 9.0 feet (2.75 m) below the finished centreline of the road

Rural Grade (Open Ditches)

- 8.0 feet (2.5 m) under deep, narrow ditches
- 9.0 feet (2.75 m) under prairie, or shallow or wide ditches
- 10.0 feet (3 m) at road crossings

All watermains both Urban and Rural Grade shall not exceed 10 feet (3.05 m) unless approved in writing by the CAO or Designated Officer.

All water service piping shall be provided with a minimum cover over the crown of the pipe, of at least 7.5 feet (2.3 m) from finished ground, but shall not be deeper than 9 feet (2.75 m), unless otherwise approved by the CAO or Designated Officer.

(c) Installation

Pipe bedding, joining and filing shall conform to the recommendations of the manufacturer, and shall conform to recognized Engineering practice. Bedding shall be tamped Class "B" (sand bedding with a minimum of 8 inches (200 mm) above crown of pipe) and backfill shall be compacted to a density equivalent to insitu material. All piping installed under proposed or existing roadways, shall be tunnelled.

(d) Valves

A gate valve shall be provided; for each fire hydrant, at the end of each block, at Provincial Trunk Highway, railway and river crossings (both sides if pipeline can flow in both directions), at watermain tees (at least two gate valves), and at watermain cross (at least three). Main line gate valves shall be installed in line with intersecting street right-of-way lines, or property lot lines, wherever possible. Maximum spacing between valves shall be 500 feet (150 m), or a maximum of 20 services between valves, whichever is less.

(e) Thrust Blocks

Thrust blocking shall be of concrete construction conforming to City of Winnipeg Standard Drawings No. SD-004 and No. SD-005.

(f) Offset Lines

Watermains shall be installed (generally) 13 feet (4 m) off the property line upon written authorization of Town.

(g) Hydrants

Hydrants shall be installed "off-line" at an offset of 2 feet (0.6 m) off the property line on the frontages (unless specified in writing differently by the CAO or Designated Officer), and 3 feet (1.0 m) off the property line on flankages. The maximum spacing of hydrants shall be such that a circle of protection is not more than a 250 foot (76 m) radius. Preference shall be



given for hydrants to be installed at road intersections, and when at an intersection, for the hydrant to be set on the least busy street, where possible. Where hydrants are located away from intersections, they shall be positioned between lots (i.e. opposite the lot line). Hydrant groundline flanges shall be between 2 inches and 6 inches (50 mm and 150 mm) above finished ground grade. Pumper nozzles shall face the nearest roadway.

Hydrants shall be installed, at a minimum, for flush out purposes regardless if fire flows are not available.

(h) Service Connections

All water service connection boxes shall be supplied and installed for new subdivision developments. Service lines shall be installed 13 feet (4.0 m) inside the property or 3 feet (1.0 m) outside utility easement, whichever is greater and plugged. The end of each installed service line shall be marked with a 2 inch x 4 inch x 144 inch long (50 x 100 x 3600 mm) pressure treated construction grade fir wooden marker, driven into the ground to full service depth, with top painted blue. A 3 foot (1.0 m) length of 3/4 inch (20 mm) rebar is to be placed next to the wooden marker, with the top being flush with the ground surface. The curb stop box shall be marked with a 6 foot (2.0 m) length of 2 inch x 4 inch x 96 inch long (50 x 100 x 2400 mm) wood marker, driven 3 feet (1.0 m) into the ground with the top painted blue. Curb boxes shall be located 12 inch (300 mm) from the front property line. **Typical water and sewer services plan and profile view drawings are shown at the end of this section in Drawing G01 and Drawing G02.**

(i) Water Main Design criteria

For domestic flow calculations, average per capita consumption of 55 I.G. (250 L) per day multiplied by the appropriate Harmon peaking factor shall be used to determine peak hour rates. Watermains shall be looped where possible to provide better pressure and eliminate stagnant water at "dead-ends". Where a main line is installed as a dead-end, a hydrant shall be installed. Watermains shall be designed to provide at a minimum the following distribution residual water pressures, when pumping station output pressure is 65 psi (450 kPa):

- domestic (community) - 50 psi (345 kPa)
- fireflow (residential) - 790 IGPM @ 25 psi (60 L/s @ 175 kPa)
- fireflow (commercial, multi-unit residential [3+ storeys] and institutional) - 1580 IGPM @ 25 psi (120 L/s @ 175 kPa)

(j) Minimum Service Size

Water service lines in communities shall be no smaller than:

Single family homes	1 inch (25 mm) HDPE
Duplex	1 inch (25 mm) HDPE for each service
Multiple unit block (8-unit max)	1 1/2 inch (38 mm)
Multiple unit block (20-unit max)	2 inch (50 mm)
Small commercial establishment	1 inch (25 mm)
Other - As determined by engineer according to individual requirements.	

(k) Testing and Disinfection

All completed works shall be tested, flushed, disinfected and re-flushed to the appropriate MWSB Standards. Water service lines shall be flushed at full operating capacity to achieve three water changes, if the lines are brought into buildings.

(l) Water Meters

Water meters must be installed on all water services connected to the Town Water Treatment Plant. Water meters can only be installed by the Town. The requirements for residential installations prior and post water meter installation are as shown in **Drawing G03** Typical Residential Water Meter Installation.

## Drawing G01 – Typical Water and Sewer Services Layout

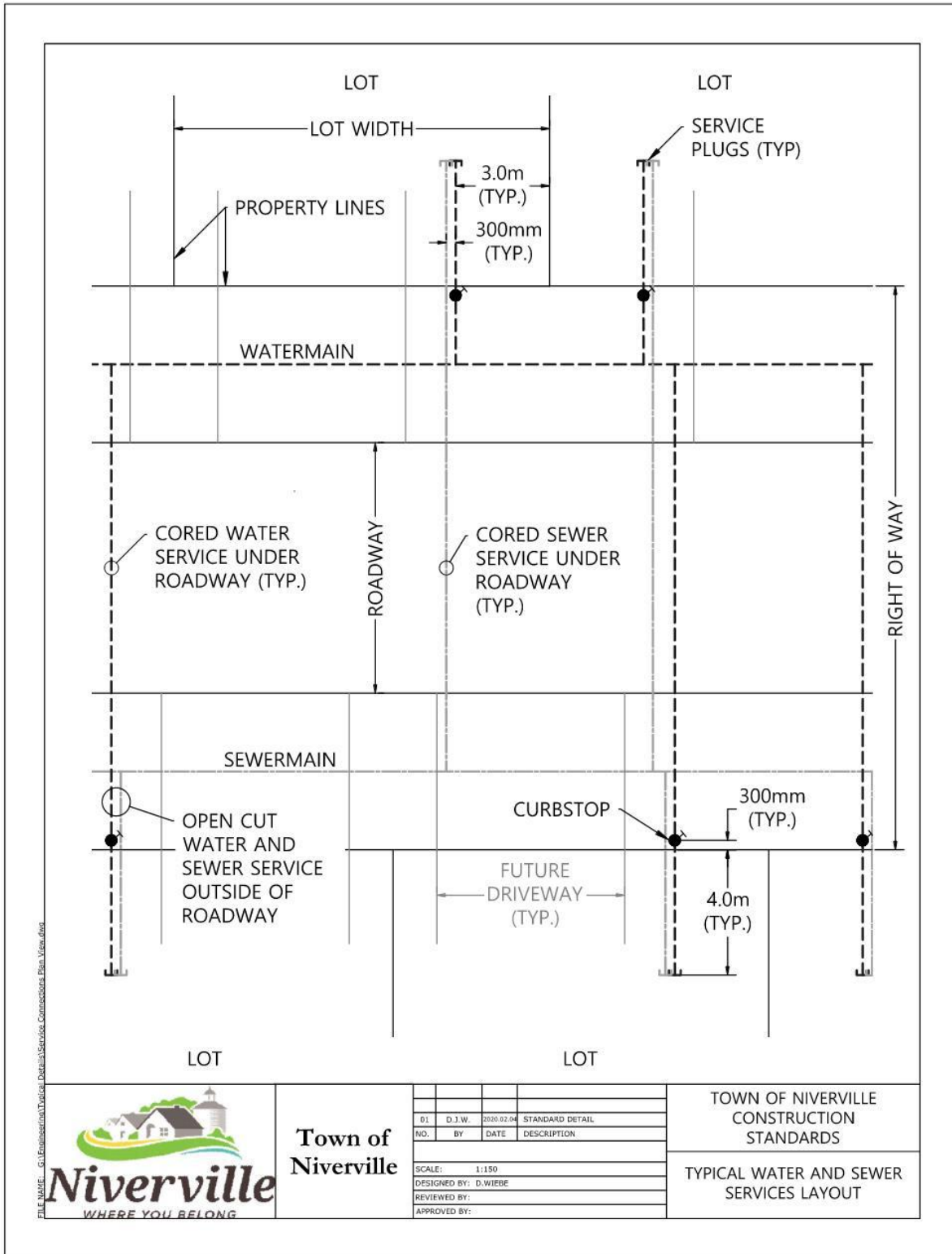

## Drawing G02 – Typical Water and Sewer Services Profile View

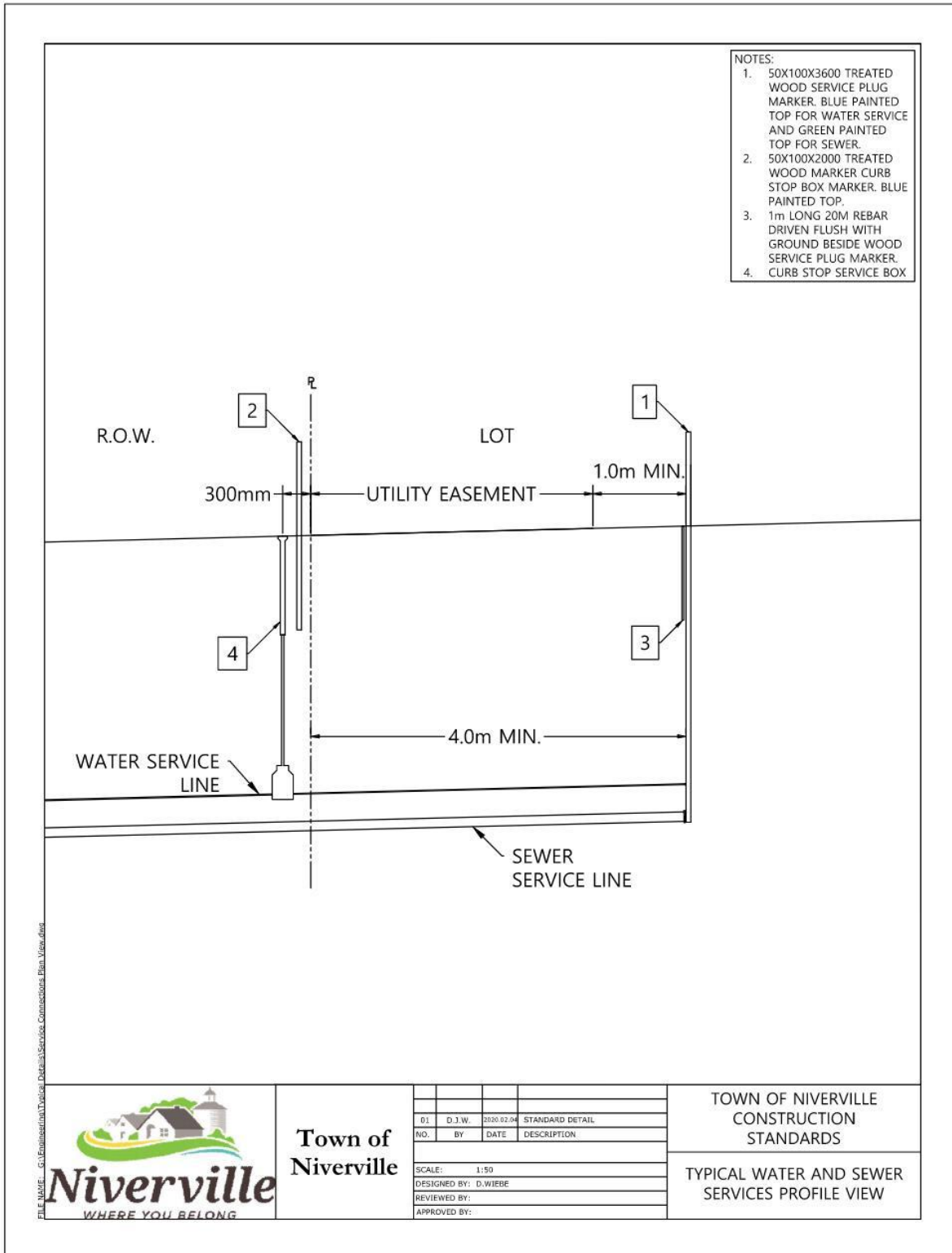

FILE NAME: G:\Engineering\Typical\_Details\Service\_Connections\_Best\_View.dwg



**Town of Niverville**

NO.	BY	DATE	DESCRIPTION
01	D.J.W.	2020.02.04	STANDARD DETAIL
SCALE: 1:50			
DESIGNED BY: D.WIEBE			
REVIEWED BY:			
APPROVED BY:			

**TOWN OF NIVERVILLE  
CONSTRUCTION  
STANDARDS**

**TYPICAL WATER AND SEWER  
SERVICES PROFILE VIEW**

## Drawing G03 – Typical Residential Water Meter Installation

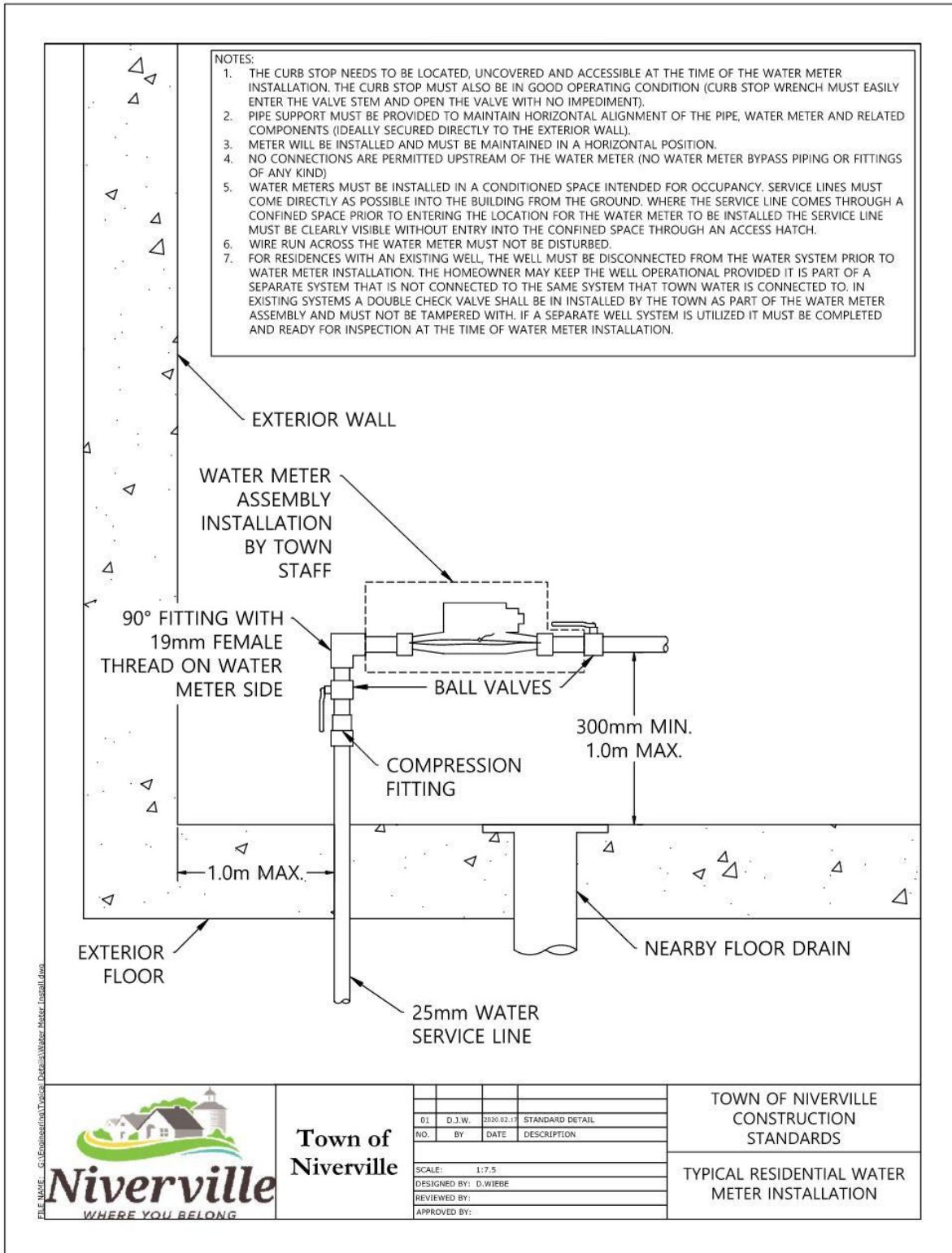

## 3.0 WASTEWATER SEWERS

### 3.1 General

#### (a) Description of Work

The work described herein shall consist of the construction of sewers including: the supply and installation of pipe, saddles, tees, elbows, plugs, manholes, the connection of the sewer to the point of discharge; and the hydrostatic leakage or infiltration testing, mandrel testing, and television inspection of the sewer as required.

'Tunnelling' shall mean augering, boring, directional drilling, pushing or coring beneath the ground surface.

#### (b) Classification of Work

SEWERS - Sewer mains shall be classified on the basis of size expressed as the nominal inside diameter, (nom. i.d.), on the basis of the class rating of the pipe (if applicable), on the basis of the installation depth, and on the basis of the class of trench backfill (in accordance with Clauses 2.4 and 3.8 of Manitoba Water Services Board Standard Construction Specifications, Section 022180, Pipe Excavation, Bedding and Backfill):

- .1 Common Backfill (if class of backfill is not specified, it shall be "common")
- .2 Compacted Common Backfill
- .3 Compacted Select Granular Backfill
- .4 Unshrinkable Backfill

SEWER SERVICE CONNECTIONS - Sewer service connections shall be classified on the basis of size expressed as the inside diameter of the sewer service pipe.

FITTINGS - Fittings (saddles, sewer service, tees, elbows, and plugs) shall be classified on the basis of size expressed as the inside diameter.

MANHOLES - There are six types of precast concrete manholes, the use of types 1, 2, 3, 4 and 5 being governed by the inside diameter of the largest sewer main in the manhole.

- .1 Type 1 - Standard for all sewer lines 200 mm to 600 mm diameter.
- .2 Type 2 - Standard for all sewer lines 200 mm to 600 mm diameter.
- .3 Type 3 - For 600 mm to 900 mm diameter lines.
- .4 Type 4 - For 1500 mm or larger diameter lines.
- .5 Type 5 - For Intersecting or Deflecting sewer mains where sewer mains are greater than 600 mm diameter.

- .6 Type 2 Drop-Style – for sewer lines 200 mm to 600 mm diameter where the difference in invert elevations exceeds one metre.

Descriptions for each type of manhole may be found in the Typical Details of Manholes, Pages 13 to 18 in MWSB Section 027030.

MANHOLE FRAME AND COVER UNITS - Frame and cover units shall be classified as either:

- .1 Solid
- .2 Open
- .3 Side Inlet
- .4 Rolled Curb and Gutter

Descriptions of each type may be found in the Typical Details of Frame and Cover Units on Pages 19 and 20 in MWSB Section 027030.

CONNECTION TO POINT OF DISCHARGE - The connection of the furthest downstream portion of the sewer to a point of discharge shall be classified as either a connection to an existing plugged sewer stub, to a manhole, or to a wet well.

(c) Standards

All materials shall conform to the relevant Standard Approval Listings of the Manitoba Water Services Board Standard Construction Specifications, most recent edition, with any exceptions being specifically outlined herein.

(d) Quality Assurance

CONCRETE - The Engineer shall carry out such tests on concrete (used to grout manholes and catch basins) as he considers necessary, in accordance with the current CSA Standard A23.2, Methods of Test for Concrete. Such tests shall be at the expense of the Owner, except that the Contractor shall furnish any and all test samples free of charge.

(e) Storage and Handling

Pipe, fittings and appurtenant materials associated with the construction of the sewers shall be stored and handled in accordance with the recommendations of the respective manufacturer or as directed by the Engineer.

(f) Inspection

Inspection of the work described in this Section shall be performed by the Engineer.

### 3.2 Products

(a) Pipe

Unless otherwise specified in The Manitoba Water Services Board Standard Construction Specifications Section 01001, Special Provisions, pipe, saddles, tees, elbows, plugs and joining products shall be as follows:

- .1 PVC - Pipe and fittings shall be manufactured of Type 1 Grade 1 Polyvinyl Chloride in accordance with the current ASTM Standard D2241, Standard for Polyvinyl Chloride Pipe, ASTM3034, Standard Specification for Type PSM Poly (Vinyl Chloride) (PVC) Sewer Pipe and Fittings, CSA B182.1 Plastic Drain and Sewer Pipe and Pipe Fittings and CSA B182.2 PVC Sewer Pipe and Fittings. Each length of pipe shall have a bell end with a rubber gasket as supplied by the pipe manufacturer. Pipe lengths shall not exceed 6 m. The pipe shall be either PVC SDR 35 or PVC SDR 28 for sewer mains, and PVC SDR 35 for sewer service connection pipe.

(b) Manholes

Manholes shall be fabricated of precast reinforced concrete in accordance with the current ASTM C478, Standard Specification for Precast Reinforced Concrete Manhole Section. Joints shall be complete with a "Ram-nek" flexible bituminous gasket. Cement used in precast concrete manhole manufacture shall be sulphate resistant meeting the current CSA Standard A5, Portland Cement, Type 50.

(c) Manhole Frame and Cover Units

Frame and cover units shall be cast iron in accordance with ASTM A48, Standard Specification for Gray Iron Castings, Strength Class 30B. Castings shall be true to the required pattern and shall be free from cracks, gas holes, flaws and excessive shrinkage. Casting surfaces shall be free from burnt-on sand and shall be reasonably smooth. Runners, risers, fins and other cast-on pieces shall be removed. Adjustment riser rings shall be used for adjusting the elevation of cover units.

(d) Concrete

Concrete used for grout and for forming benching channels in manholes shall have a 28-day compressive strength of not less than 15 MPa. Cement used in concrete shall be sulphate resistant meeting the current CSA



Standard A5, Type 50 Portland cement. Water used for mixing concrete shall be clean and free from injurious amounts of oil, acid, alkali, organic matter or other deleterious substances. It shall be equal to potable (suitable for drinking) water in both physical and chemical properties.

(e) Gaskets and Lubricants

Gaskets and lubricant used to join pipes and fittings shall be of a type compatible with the particular pipe or fitting being used.

(f) Sewermain Insulation (Shallow Bury)

When in areas of shallow trench, it shall be necessary to provide insulation over the top and sides of the pipe. Subterra Plus 40 type 3 or conforming to CAN ULC S701-97 or approved equal with a compression strength of 275 kPa shall be used. A typical pipe insulation detail is shown on page 21 of MWSB Section 027030. In the case of two pipes insulated in a common trench the insulation shall envelope both pipes.

(g) Rungs

Rungs shall be cast into the manhole precast concrete sections every 305 mm and shall be made in accordance with CSA G30.12, No. 25M Billet steel deformed bars, hot dipped, galvanized to CSA G164. Aluminium ladder rungs may also be used. Rungs shall be safety pattern (drop step type).

### **3.3 Execution**

(a) Excavation and Bedding Backfill

This portion of the work shall be in accordance with Manitoba Water Services Board Standard Construction Specifications, Section 022180, Pipe Excavation, Bedding and Backfill.

(b) Grade and Alignment

Sewer pipe shall be installed to the line and grade shown on the Plans and as set in the field by the Engineer. Vertical variance from grade shall not exceed the following limits; the invert of the pipe shall not be more than 1 inch (25 mm) below the design grade nor more than 1 inch (25 mm) above the design grade and there shall be no dips which will allow ponding of water to a depth of more than 2 inches (50 mm). Horizontal variance from line shall not exceed 4 inches (100 mm). Sharp bends will not be permitted even though the sewer pipe remains within these tolerances.

Manholes, tees, wyes, reducers and bends shall be installed to the grades and at the locations shown on the Plans. The allowable tolerance from the line and grade shall not exceed those specified for sewer pipe.

(c) Cleaning

Prior to installation, all interior and joining surfaces of all pipes and fittings shall be cleaned of dirt and foreign material and wiped dry.

(d) Joining PVC Pipe

The pipe shall be installed with the bell end facing upstream unless otherwise specified by the Engineer. An integral rubber gasket shall be supplied in the bell end of the pipe. The manufacturer's recommended lubricant shall be applied to the bevelled spigot end. The spigot end shall be inserted into the bell end of the previously laid pipe to the stop mark which the manufacturer provides on the spigot end, such that a secure joint is obtained.

(e) General Joining Procedure

Spigot or tongue ends of pipe may be inserted into the bell, coupling or groove ends of previously laid pipe by hand, or if additional force is required to effect complete insertion, the following may be used:

- .1 BAR AND BLOCK - If a bar is used for leverage, a wooden block shall be placed between the bar and the end of the pipe being pushed.
- .2 LEVER-TYPE OR FRICTION PULLERS - When pullers are used, the chains shall be employed in a manner which does not cause damage to the pipe.

(f) Tunnelling

Where the sewer is to be installed by means of auguring, coring, pushing, or directional boring rather than by open cut trenching, the tunnel shall be of a diameter large enough to enable the pipes to be pushed through without interference or obstruction. The pits at either end of the tunnel shall be of adequate length to allow each pipe length to be lowered in parallel to the tunnel and joined to the length of pipe installed previously. The bell, coupling or grooved end of the previously installed pipe shall extend clear of the tunnel opening and be completely exposed to facilitate joining. The pipe lengths shall be securely joined in accordance with specifications of this Section; whichever is appropriate.

(g) Cutting Pipe

If it is necessary to shorten a length of sewer pipe, the pipe shall be cut with a fine-toothed hand saw, power saw (quickie saw) or hack saw, but not with a chain saw. Cut ends of PVC pipe shall be bevelled to the correct outside diameter with a fine file to duplicate the factory bevel on the spigot end of the pipe.

(h) Manholes

Manholes shall be constructed in accordance with the typical manhole, Pages 13 to 18 of MWSB Section 027030 with the following exceptions.

"Ram-nek" flexible bituminous gaskets shall be installed on each manhole section prior to lowering the section into the trench. Sections shall be lowered with care and properly aligned to ensure that all ladder rungs line up vertically.

A flat top ring shall be installed on the riser just prior to the frame and cover unit. A minimum of 2 x 75mm adjustment rings shall be installed under the manhole frame and cover for future elevation adjustment.

Subsequent to the installation of the precast concrete sections and frame and cover unit, all joints and holes for lifting lugs shall be sealed on the inside with grout.

TYPE 1, 2 AND 5 MANHOLES - The manufacturer shall precast in or core in holes and install a flexible connector boot where the sewer pipe is to be installed by the contractor. Manholes are to pre-benched with semi-circular channel(s) with the same inner radius as the incoming and outgoing pipes with vertical sides up to the top of the incoming and outgoing pipes. The benching shall have a slope of 10:1 and the channel shall have positive slope to the outgoing pipe. The benching shall allow the incoming and outgoing pipes to go completely through manhole walls with pipe inverts matching the bottom of the pre-benched channel. When the Contractor installs PVC sewer pipe through the precast concrete manhole walls they shall ensure a water tight connection by securing the flexible connector boot to the pipe and grouting the pipe to the surrounding manhole and benching.

TYPE 1, 2, 3 AND 4 MANHOLE - The joints of the manhole pipe and stack unit shall be grouted externally and internally.

TYPE 2 - DROP MANHOLES - Drop manholes shall be constructed with tee and elbow sections encased in concrete as shown on the Typical Drop Manhole Detail, Page 18 of MWSB Section 027030.

(i) Connection to Point of Discharge

EXISTING PLUGGED SEWER - The plug shall be removed from the existing sewer. A new gasket shall be installed to join the existing pipe with the new pipe. Where the two pipes consist of different materials, a secure joint shall be made by installing an approved coupler or adaptor connecting the new to the existing sewer pipe

EXISTING MANHOLE – Shall follow the same standards as per new manholes with the following exceptions. The contractor may core the new hole on site. A new link seal or flexible boot shall be installed in the cored hole to the new sewer line to ensure a water tight connection between the manhole, the flexible boot or link seal and the new pipe. If a semicircular channel does not already exist in the bottom of the manhole to receive flow from the new pipe, one shall be formed as per the pre-benching standards above and grouted in place with jack hammering the existing benching as required. All rubble resulting from these operations is unsuitable material and shall be disposed of by removing it from the manhole.

EXISTING WET WELL - An existing wet well may be either a lift station, a portion of a sewage treatment plant, or a chamber. An opening shall be made through coring a hole in the wall of the wet well. A link seal or flexible boot shall be installed to ensure a watertight seal between wet well, the link seal or flexible boot and the new pipe. The pipe shall be cut flush with the inside wall.

(j) Service Connections

Service lines shall be connected to the sewer mains by means of either an in-line tee or a saddle. Tees shall be installed on new sewer installation and saddles may be used on infill connections. Tees shall be installed by the same method as is used to join the sewer main pipe. All saddles except PVC saddles shall be installed on the main and grouted in place using sulphate resistant cement for concrete. Appropriate cutting tools shall be employed to cut a hole in the main for the service line prior to the installation of the saddle. PVC saddles shall be installed by means of the solvent-weld cement (in the case of solvent weld saddles) on PVC sewer main, complete with two all-stainless-steel clamps. Saddles utilizing a gasket only, shall be installed in accordance with manufacturers' recommendations and two all-stainless-steel clamps. Refer to Sewer Service Connection Detail on Page 12 of MWSB Section 027030.

Elbows shall be used as required to connect service line pipe to the tee or saddle on the sewer main. Riser pipe shall be used as required to join sewer service lines to deep sewer mains.

The end of each service line (which normally terminates at the limit of the road right-of-way) shall be sealed with an appropriate plug and a marker post installed at the ground surface.

(k) Temporary Plugs

During prolonged pauses in the construction, such as meal breaks and overnight, the sewer lines shall be temporarily plugged with an approved plug to prevent the entry of foreign matter.

(l) Mandrel

All PVC sewer mains shall be subject to a mandrel test with a rigid device sized to pass 5% or less deflection (deformation) after backfilling of the trench over the pipe. The deflection following trench consolidation shall not be greater than 7.5 per cent. The mandrel shall be supplied by the Contractor and reviewed by the Engineer. No allowance shall be made for pipe wall thickness tolerances or ovality (from heat, shipping, poor production, etc). The above shall be counted in as part of the deflection allowance. The mandrel shall be hand pulled by the Contractor through the sewer lines. Any sections of sewer not passing the mandrel test shall be excavated and the Contractor shall re-install or replace the sewer main to the satisfaction of the Engineer. The repaired sections shall be retested. The inspection shall be conducted no earlier than 30 days after reaching final trench backfill grade, provided in the opinion of the Engineer that sufficient water densification or rainfall has occurred to thoroughly settle the soil throughout the entire trench depth.

If densification cannot be achieved in the time after installation prior to the project completion date, then the mandrel size shall be increased so that the rigid mandrels device would be sized to pass 4 percent or less deflection (deformation of the pipe diameter).

(m) Ball Testing

All sewers (excepting those where the Engineer requires mandrel testing) shall be subject to ball testing by the Contractor.

Ball testing shall comprise pulling a wood or metal ball through sewer lines between manholes, such a ball being 50 mm smaller in diameter than the internal diameter of the sewer being tested. If the ball does not pass readily through the sewer, the Contractor shall repair or replace or clean the defective sewer at the Contractor's expense and the test shall be repeated.

(n) Television Inspection

The Contractor shall provide a television inspection of all installed wastewater sewers. The television inspection shall be complete with video recording of all completed gravity sewer mains which have an internal diameter of 4 feet (1200 mm) or less.

The television inspection shall be done by personnel skilled and qualified in the use of the television inspection equipment. All televising equipment shall be the most current video format. The Contractor shall supply the videos and summary report in electronic format on two USB sticks, one for the Town and one for the Engineer. Inspection shall be between manholes or other appropriate locations where the equipment may be installed or removed. The section to be inspected shall not be broken down into units smaller than the distance between manholes or other appropriate locations as detailed above. The sewer shall be cleaned before the television inspection is done.

If the television inspection indicates areas of repair are required, it shall be re-televised when the repair is complete, and a minimum of 30 days after the repair is complete and backfilled, or alternately, prior to the expiration of the warranty period.

## 4.0 LOW PRESSURE SEWERS

### 4.1 Materials

(a) General

All materials and construction methods for low pressure sewers shall conform to the relevant sections of the Manitoba Water Services Board (MWSB) Standard Construction Specification, latest edition.

(b) Sewer main Pipe

Low Pressure Sewer (LPS) mains shall be either PVC SDR 32.5 Series 125 (CSA B.137.3) or high-density Polyethylene (HDPE) Series 60 (75 for 3 inch diameter and smaller) (CSA B.137.1).

(c) Fittings

LPS fittings shall be made of the same material and to the same specifications as the sewer main pipe.

(d) Valves and Boxes

3 inch (75 mm) and larger - (See 2.1(d) and (e)). Iron hinged box covers shall be cast with the mark "S".

(e) Service Pipe

LPS service pipe shall be 1 1/4 inches (32 mm) low density PE Series 75 (CSA B.137.1).

(f) Curb Stops and Boxes (and 2 inch (50 mm) valves)

(See Section 2.1(i) and (j)). The word "sewage" shall be cast into the iron box lid.

(g) Couplings

(See Section 2.1 (k) for connection to PVC mains) For P.E. mains, P.E. fittings shall be of same quality and pressure rating as pipe. Injection moulded or fabricated with FRP reinforcement for both thermal butt fusion and socket fusion application. Acceptable models shall be Ford FC-1 (to have ESH designation) or Viking Johnson / Mueller "Maxi-fit" or "Maxi-step" (c/w all stainless-steel nuts, bolts and washers, or approved equal.

(h) Cleanouts

Cleanout assemblies shall consist of a 2 inch (50 mm) valve and riser PVC pipe to the surface, with a threaded cap. The pipe, valve and fittings shall conform to the relevant section of this specification.

(i) Service Saddles

Service connection saddle/clamp assemblies shall be compression type with a rubber gasket that fully contacts the pipe surface. Saddles shall be brass, bronze, or stainless steel. Electrofusion tapping sleeves will be acceptable on P.E. mains. Acceptable models shall be Robar "Series 1616", Romac 306, Ford Stainless Steel FS303, Ford Brass S70 and S90, or approved equal.

## 4.2 Design and Construction

(a) General

Subsections (a), (b), (c) and (e) of Section 2.2 shall apply.

(b) Valves

Valves shall be provided where branch mains connect to a main collector. Main collectors shall be provided with a valve and box upon entering a sewage pumping station, or a stabilization pond; at Provincial Trunk Highway, railway and river crossings; and at significant points (i.e. where main collectors join).

(c) Discharge

A low pressure sewer main shall only discharge to the following:

- Another low pressure sewer main with sufficient capacity
- Sewage pumping station
- Stabilization pond
- Gravity sewer manhole, providing all downstream piping is PVC (no concrete).

(d) Cleanouts

Cleanouts should be provided at 90-degree bends or intersections, and at the end of branch lines, but may be omitted if the branch line will serve no more than three houses or if the branch line is certain to be extended within three years, as determined by Council. Cleanouts should be provided along LPS mains where significant low points occur (i.e. river crossings). Maximum spacing between cleanout locations shall be 1500 feet (450 m).



(e) LPS Main Design criteria

While sophisticated pressure analysis models may be employed to determine precisely the anticipated flows/pressure losses for line sizing, the minimum size, in relation to the maximum potential number of service connections, is as follows:

<u>Main size</u>	<u>Max. No. of Services</u>
2 inch (50 mm)	40
3 inch (75 mm)	70
4 inch (100 mm)	120

These numbers assume no weeping tiles are connected. For pressure loss/flow calculations, the performance characteristics of the Monarch BE50 pump shall be used. "Wastewater production" rates shall be as per Section 3.2(f).

(f) Testing

All completed works shall be tested to MWSB standards except that the test pressure shall be 75 psi (500 kPa).

(g) Service Connections

All rural and urban low-pressure sewer service lines shall be installed 13 feet (4.0 m) inside the property line and plugged. If there is no water service line installed, the end of the low-pressure sewer line and curb stop box shall be marked as per section 2.2 (h).

## 5.0 DRAINAGE CRITERIA

### 5.1 Approved Materials for Drainage Installations

All drainage construction methods and materials shall conform to the City of Winnipeg Standard Construction methods, most recent edition, with and exceptions being specifically outlined herein.

#### (a) Culverts

Drainage culverts shall be HDPE unless written approval for a steel culvert is provided by the CAO or Designated Officer. HDPE culverts shall be dual wall and have a minimum pipe stiffness of 210 kPa at 5% deflection. Should a steel culvert be approved, it shall be corrugated steel pipe, minimum 16 gauge (1.6 mm total thickness), coated with 2 oz, zinc per square foot (610 grams per square metre), joined with annular corrugated couplers. Minimum size shall be 12 inch (300 mm) diameter. **All driveway culverts will require a municipal permit before installation.**

See [Drawing G04](#) for culvert installations requirements.

#### (b) Storm Sewer Piping

Storm sewer pipe shall be:

- Corrugated HDPE (Boss 2000 or approved equal) to CSA B182.6 storm sewer or PVC Ribbed (Kor-Flo, or approved equal).
- Kor-Flo not approved beyond 36 inches (900 mm) diameter. Kor-Flo must have a minimum cover of 24 inches (600 mm) and cannot be buried deeper than 13 feet (4.0 m).
- Concrete pipe up to and including 15 inch (375 mm) diameter shall be Class 3 pipe as designated by ASTM Standard C14.
- Concrete pipe greater than 15 inch (375 mm) diameter shall be the class specified by the engineering consultant and as approved by the CAO or Designated Officer. Classes shall conform to ASTM Standard C14 and C76.
- PVC SDR 35 (ASTM D3034 or F679).

#### (c) Manhole and Catch Basin

Storm sewer manholes and catch basins shall be precast reinforced concrete (ASTM C76 Class II). Manhole sections shall have flexible bituminous gaskets between sections. Cement shall be CSA A5M Type 50, sulphate resistant. Units shall have cast-in-place aluminum or galvanized steel ladder rungs at 12 inch (305 mm) spacings. Standard manhole base

## Drawing G04 – Typical Culvert Detail

**NOTES:**

1. ADDITIONAL EXCAVATION AND BASE OR GEOSYNTHETICS SHALL BE USED TO STABILIZE THE TRENCH BOTTOM WHERE REQUIRED BY THE ENGINEER.
2. NON-WOVEN GEOTEXTILE SHALL BE USED TO LINE THE PIPE BEDDING AND INITIAL BACKFILL WHERE MIGRATION OF FINES IS POSSIBLE.
3. BEDDING IS TO BE COMPACTED ON EITHER SIDE OF THE PIPE BUT REMAIN LOOSE WHERE PIPE IS TO BE PLACED.
4. INITIAL BACKFILL SHALL BE TAMPED AROUND THE HAUNCHES OF THE PIPE AND FILL IN AROUND ALL PIPE CORRUGATIONS UP TO THE SPRINGLINE.
5. INITIAL BACKFILL SHALL BE WELL GRADED COMPACTED GRANULAR MATERIAL OR SAND AND REMAIN THE SAME MATERIAL TYPE THROUGHOUT THE INITIAL BACKFILL LAYER.
6. FINAL BACKFILL MUST BE GRANULAR IN ROADWAY APPLICATIONS, OTHERWISE IT MAY BE NATIVE FILL.
7. A CLAY CAP OF 300mm [1 FOOT] SHALL BE PROVIDED AT EACH END OF THE CULVERT.
8. DISTURBED AREAS AT CULVERT ENDS SHALL BE GRADED TO A MIN. SLOPE OF 4:1 AND GRASS RE-ESTABLISHED.
9. MANUFACTURER RECOMMENDED SOIL TIGHT OR BETTER PIPE CONNECTIONS SHALL BE UTILIZED WHERE JOINING SECTIONS OF PIPE.

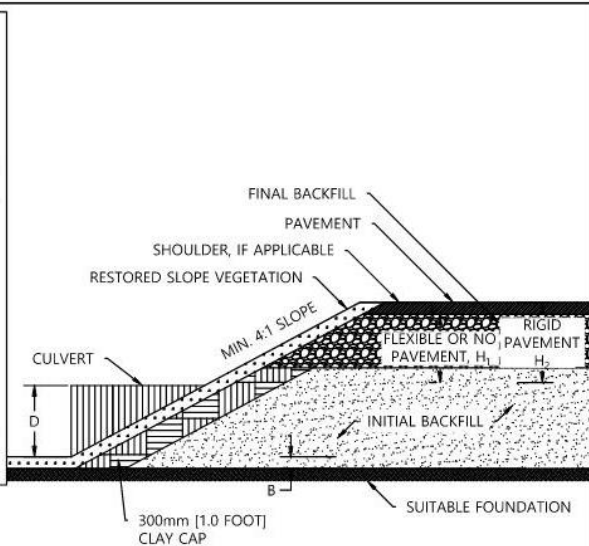

**PROFILE VIEW**  
1:50

PIPE DIAMETER, D		MIN. SLOPE	MIN. COVER H1 & H2		BEDDING, B		MIN. TRENCH WIDTH, W	
[mm]	[INCH]	[%]	[mm]	[INCH]	[mm]	[INCH]	[mm]	[INCH]
300	12	0.440	300	12	100	4	750	30
375	15	0.320	300	12	100	4	850	34
450	18	0.250	300	12	100	4	1000	39
600	24	0.170	300	12	100	4	1200	48
750	30	0.130	600	24	150	6	1400	56
900	36	0.100	600	24	150	6	1600	64
1050	42	0.082	600	24	150	6	1800	72
1200	48	0.069	600	24	150	6	2000	80
1500	60	0.051	600	24	150	6	2450	96

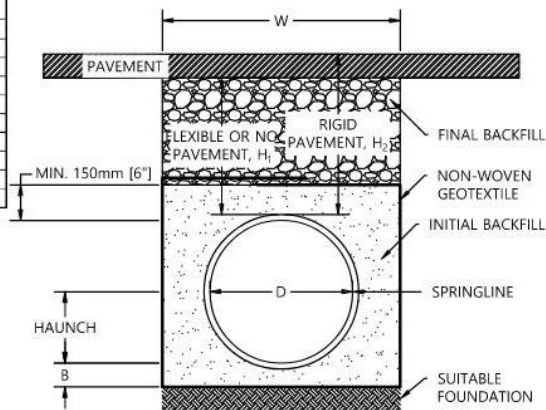

**CROSS SECTION VIEW**  
1:25

FILE NAME: G:\Engineering\Typical Details\Culvert\_Detail.dwg



**Town of Niverville**

NO.	BY	DATE	DESCRIPTION
01	D.J.W.	2021.02.17	ISSUED FOR REVIEW

SCALE: VARIES  
 DESIGNED BY: D. WIEBE  
 REVIEWED BY:  
 APPROVED BY:

**TOWN OF NIVERVILLE  
CONSTRUCTION  
STANDARDS**

**TYPICAL CULVERT  
DETAIL**

sections shall be 48 inch (1200 mm) diameter with a 48 inch (1200 mm) diameter riser section. Flat top reducers shall be permitted if site conditions will not permit the installation of a conical reducer. Catch basins shall be 36 inch (900 mm) diameter and have 24 inch (600 mm) sumps. No hinged cast iron or PVC hoods are to be installed.

(d) Frost heaving protection

Ensure approved geotextile is laid in the base and a minimum of 2 feet (600 mm) of 2 inch (50 mm) clean limestone is placed beneath the bottom of the catch basin. The barrel shall be wrapped in 4 inches (100 mm) rigid non compressible insulation (laid in 2 x 2 inch (50 mm) layers with staggered joints) a minimum of 3 feet (1.0 m) from the base of the catch basin. Halo Subterra Plus 40 type 3 or conforming to CAN ULC S701-97 or approved equal with a compression strength of 275 kPa shall be used. Frost heaving protection for catch basins is shown at the end of this section, as part of **Drawing G05**.

(e) Manhole and Catch Basin Covers/Inlets

Catch basin and storm sewer manhole framing and cover units shall be cast grey iron, true to the required pattern, free of cracks, gas holes, flaws, and excessive roughness. Minimum frame weight shall be 103 kg and minimum cover weight shall be 76 kg. Patterns shall be Titan TF101M, TF 102 (rolled curb unit), TF 103-3 (barrier curb unit), as required, or approved equal. Cover openings shall be herringbone or "V" style to be compatible with bicycle traffic. A minimum of 2 x 3 inch (75 mm) adjustment rings shall be installed under the manhole frame and cover for future elevation adjustment.

(f) Roadway Drainage

On curb and gutter streets, catch basins shall be placed outside of the roadway and a catch basin approach shall be constructed as per **Drawing G05**.

Roadway edge sub drains shall be provided as per **Drawing G06**. On curb and gutter streets, a minimum of 9 feet (3 m) of sub drain shall be provided on either end of each roadway catch basin in the direction of traffic. On roadways where ditches prevail a minimum of 9 feet (3 m) of sub drains shall be provided at either side of the road every 150m, at all low points, or at each intersection, whichever is greater. At each sub drain location, outlets shall be provided to either existing culverts or directly to the ditch.

(g) Grade and Alignment

Grade and alignment tolerances shall be as per section 3.3(b). Inspection shall be completed using televised inspection as per section 3.3(n).

## Drawing G05 – Typical Roadside Catch Basin Detail

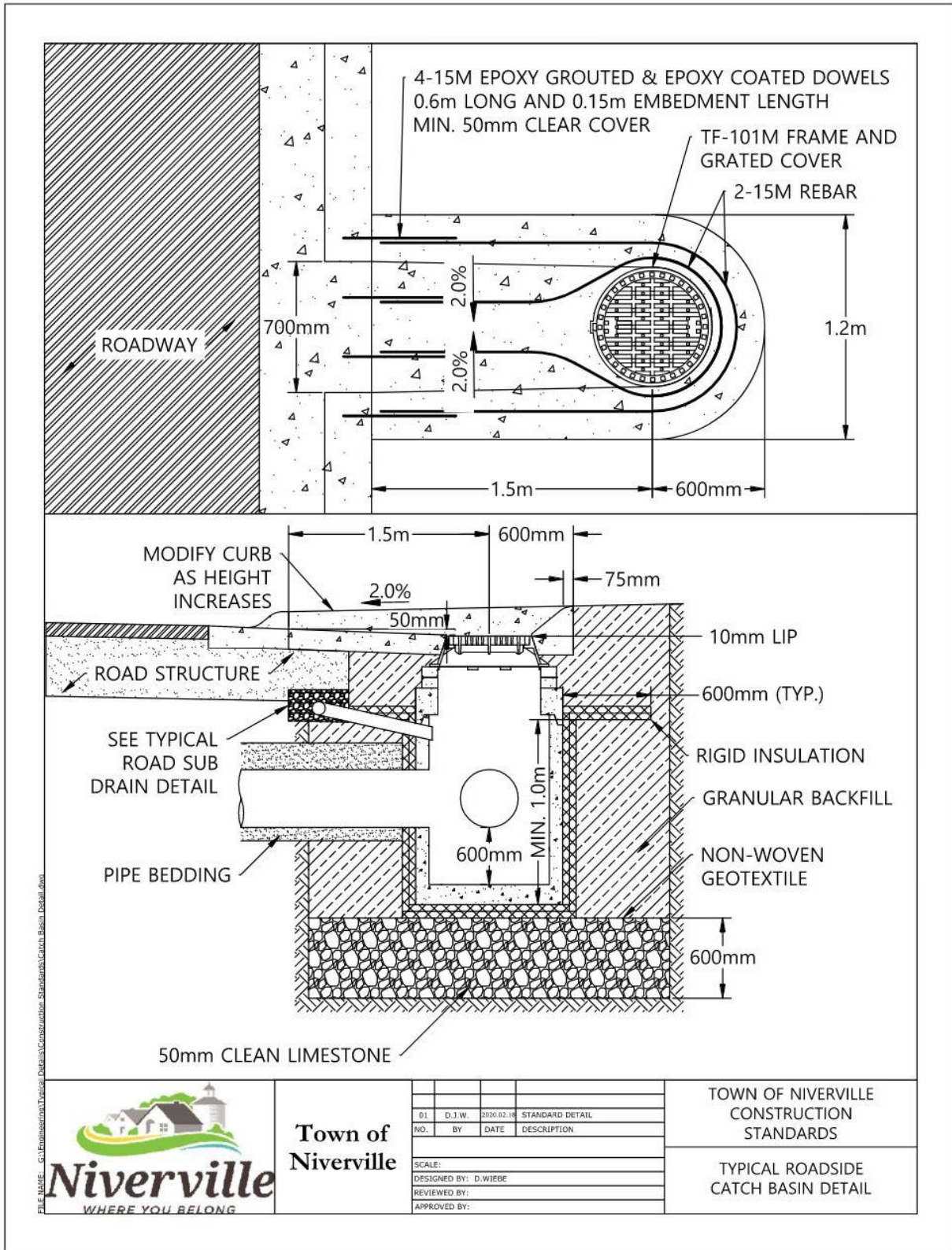

## Drawing G06– Typical Road Sub Drain Detail

**NOTES:**

1. NON-WOVEN GEOTEXTILE SHALL COMPLETELY ENCLOSE THE DRAIN STONE AND SHALL OVERLAP ITSELF BY A MINIMUM OF 450mm [18"].
2. A LEVELING COURSE OF DRAIN STONE APPROXIMATELY 50mm [2"] SHALL BE PROVIDED FOR THE PIPE.
3. PERFORATED AND SOLID PIPE SHALL BE 100mm [4"] OR 150mm [6"] IN DIAMETER.
4. THE CROWN OF THE PERFORATED PIPE IS TO BE PLACED AT OR BELOW THE BOTTOM OF THE MAIN ROAD STRUCTURE SUBBASE AND SHALL FOLLOW THE LONGITUDINAL GRADE OF THE ROADWAY.
5. DRAIN STONE SHALL BE POORLY GRADED NATURAL ROUND OR CRUSHED ROCK FREE OF DELETERIOUS MATERIAL WITH LESS THAN 5% PASSING THE 12500  $\mu$ m SIEVE.
6. FOR CURB AND GUTTER STREETS, THE PIPE OUTLET SHALL PENETRATE THE CATCH BASIN BY A MINIMUM OF 50mm [2"] AND A WATER TIGHT SEAL SHALL BE PROVIDED AROUND THE PIPE PENETRATION. FOR STREETS WITH DITCHING, THE OUTLET PIPE SHALL BE SOLID AND CUT FLUSH WITH THE OUTLET SLOPE. THE TOP END OF THE DRAINAGE PIPE SHALL BE CAPPED.
7. ONLY PIPE FITTINGS OF 45° AND LESS WILL BE PERMITTED.
8. MANUFACTURER RECOMMENDED SOIL TIGHT OR BETTER PIPE CONNECTIONS/FITTINGS SHALL BE UTILIZED.

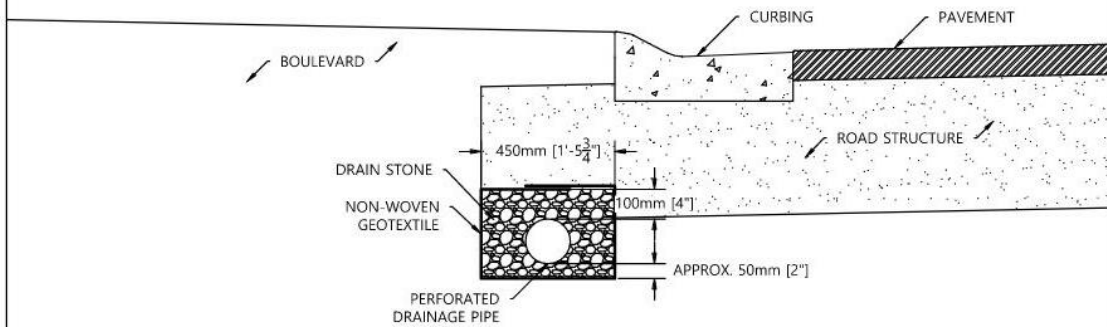

**CURB AND GUTTER CROSS SECTION**

1:20

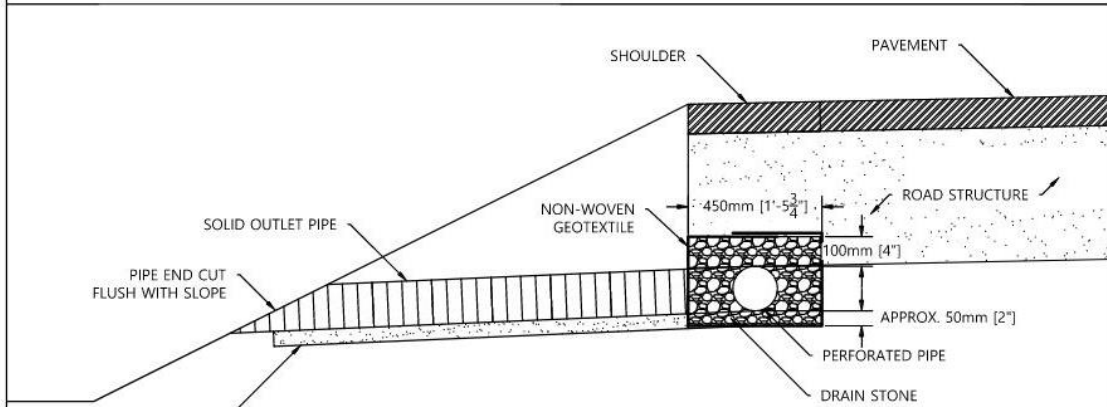

**DITCH CROSS SECTION**

1:20

FILE NAME: G:\Engineering\Typical Details\Road Sub Drainage.dwg



**Town of Niverville**

NO.	BY	DATE	DESCRIPTION
01	D.J.W.	2021.02.18	ISSUED FOR REVIEW

SCALE: 1:20  
 DESIGNED BY: D.WIEBE  
 REVIEWED BY:  
 APPROVED BY:

**TOWN OF NIVERVILLE  
CONSTRUCTION  
STANDARDS**

**TYPICAL ROAD SUB  
DRAIN DETAIL**

## 5.2 Design Criteria

### (a) System Capacity and Drainage Design

Stormwater drainage works, including ditches, culverts, and storm sewers, shall be designed on the basis for rainfall intensity statistically equivalent to a five-year return interval, with duration equivalent to the time of runoff concentration to any given point in the system. Based on this calculated intensity, the rate of storm runoff shall be determined by the Rational Formula for drainage areas less than 100 acres. For larger areas, or alternate means of calculating peak discharge, approval must be received by the Town.

### (b) Storm Sewers

- Storm sewers to be designed to accommodate a 5-year return design rainfall.
- Storm sewers to accommodate estimated peak flows under surcharged conditions and as identified within section (a) above.
- Under design conditions, the maximum permissible surcharge level shall be the gutter elevation within the drainage basin.
- Storm sewers shall have a minimum diameter of 12 inches (300 mm). Catch basin lead piping shall have a minimum diameter of 10 inches (250 mm).
- Storm sewers shall be designed with a slope to provide minimum velocities when flowing full of 3 feet (0.9 m) per second, using the Manning roughness coefficient 'n'=0.013.
- Storm sewers shall have a minimum depth of cover of 5 feet (1.5 m) to invert below proposed ground elevation immediately above storm sewer alignment.

### (c) Drainage Ditches

Drainage ditches shall be graded at a longitudinal slope of 0.20% or greater. Typical side slopes shall be no steeper than 4:1 unless otherwise approved by the Town. Ditch bottoms shall be at least 39 inches (1.0 m) wide. "V" ditches shall not be acceptable unless approved by the Town. Ditches, which includes the entire area between the edge of the road and the property line, shall be seeded with grass.

### (d) Stormwater Retention

All new developments shall be required to provide on-site storage to store the difference between a 1 in 5-year pre-development storm hydrograph and a 1 in 25-year post development storm hydrograph with a duration of 3



hours. Maximum allowable outflow rate during a 1 in 25-year storm is the peak flow during 1 in 5-year pre-development storm. Infill development stormwater retention requirements shall be reviewed on a case-by-case basis and may vary from the above.

All ponds/lakes used for stormwater retention in the Town of Niverville shall be constructed following the City of Brandon Naturalized Stormwater Pond Guidelines which can be referenced at: <http://brandon.ca/what-is-happening-in-your-neighbourhood/active-projects/1322-naturalized-stormwater-retention-basin-s>.

## 6.0 ROADWAYS

### 6.1 General

Roadways shall be classified as either residential or collector or commercial (light duty or heavy duty). All roadway construction methods and materials shall conform to the City of Winnipeg Standard Construction methods, including excavation, sub-base, base course, and asphalt, most recent edition, with and exceptions being specifically outlined herein. Compaction requirements shall be based on Standard Proctor Dry Density (ASTM D698) at 90-130% of optimum moisture content.

### 6.2 Pavement Design Criteria

(a) Gutter Grade

Where gutters are provided, they shall be graded at a minimum slope of 0.4%.

(b) Crossfall

The highpoint of the pavement shall be the centre-line of the road (crown). The crossfall between crown and gutter shall be graded at 2.0% for urban roads. Rural roadways with no curb and gutter shall be graded at 4.0%.

(c) Width

Residential roadways and light duty commercial shall be 27 feet (8.23 m) wide, collector and heavy duty commercial roadways (unless otherwise specified by the CAO or Designated Officer shall be 33 feet (10.06 m) wide, as measured from the outside edge of the curbs. Corners shall be a minimum 24 foot (7.5 m) radius for residential and collector pavements, and 33 foot (10.0 m) radius for commercial pavements.

Where there are no curbs or gutters, the minimum width shall be as above, plus 36 inches (0.9 m) of shoulder on either side.

Where there is, a right-of-way widening on curves, the outside road radius shall be 39 feet (12.0 m).

Developers shall ensure that right-of-way widths are adequate to accommodate the appropriate utilities, infrastructure piping, road width, and ditches stipulated in these standards. However, minimum right-of-way widths shall be 66 feet (20.0 m) for residential and light commercial, and 80 feet (24.0 m) for collector and heavy duty commercial roads.

(d) Lanes

Residential lanes shall have a concrete pavement width of 20 feet (6.1 m), and a right-of-way width of 26 feet (7.9 m). The crossfall to the centre v-drain shall be 3.0%. Corners shall be a minimum 15 foot (4.5 m) radius. Minimum longitudinal slope for the v-drain shall be 0.5 %.

(e) Multi-family Developments

Roadways within multi-unit developments shall have minimum 25 feet (7.6 m) aisle width plus 5 foot (1.5 m) buffer.

### 6.3 Subgrade

- (a) Excavations for roadways shall be, at minimum, three feet (0.9 m) wider than the outside design width of the pavement. Excavation shall be sufficiently deep to permit the required subgrade preparation, base course and pavement thickness. Subgrade preparation shall conform to City of Winnipeg practice. This generally consists of removing a 6 inch (150 mm) layer of subgrade (under bottom subbase course level) and recompacting it into place to minimum 95% density with a sheep's foot roller and/or vibrating compactor. Any unsuitable material (organics, silty soil, etc.) as may be exposed shall be excavated and removed, to a maximum depth of three feet (900 mm), and replaced with compacted clean clay, or other approved subbase material.

Where embankment is required for the road to meet the design grades, it shall be either:

1. Clean compacted clay
2. Crushed limestone sub-base (50 mm) compacted to 100% density
3. Crushed limestone sub-base (100 mm or 150 mm). This material to be used only if the thickness of the material to be placed is a minimum of 2.5 times the diameter of the aggregate to be placed

### 6.4 Pavement Sections

Granular pavement section shall consist of a minimum asphalt, subbase and base course thickness as indicated for urban roadways:

- a) Residential
- 4 inches (100 mm) asphalt
  - 6 inches (150 mm) base course
  - 12 inches (300 mm) subbase
- b) Collector
- 4 inches (100 mm) asphalt
  - 6 inches (150 mm) base course

- 16 inches (400 mm) subbase
- c) Commercial (light duty)
  - 4 inches (100 mm) asphalt
  - 8 inches (200 mm) base course
  - 16 inches (400 mm) subbase
- d) Commercial (heavy duty)
  - 4 inches (100 mm) asphalt
  - 12 inches (300 mm) base course
  - 18 inches (450 mm) subbase
- e) Residential Lanes
  - 6 inches (150 mm) reinforced concrete
  - 12 inches (300 mm) base course

Granular materials shall be placed and compacted in lifts to achieve a minimum 100% density throughout the subbase pavement structure. The subbase and base course materials shall be crushed limestone aggregate to meet City of Winnipeg standards.

## 6.5 Geotextile Fabric

- .1 Acceptable products Armtec 855 or W315 woven
- .2 All joints shall be overlapped a minimum of 2 feet (0.6 m) on edges, and three feet (1.0 m) on ends. **The geotextile shall be rolled out parallel to the roadway lanes.**

Typical road cross sections are shown on **Drawing G07**.

Typical lane cross section is shown on **Drawing G08**.

## Drawing G07 – Typical Road Cross Section

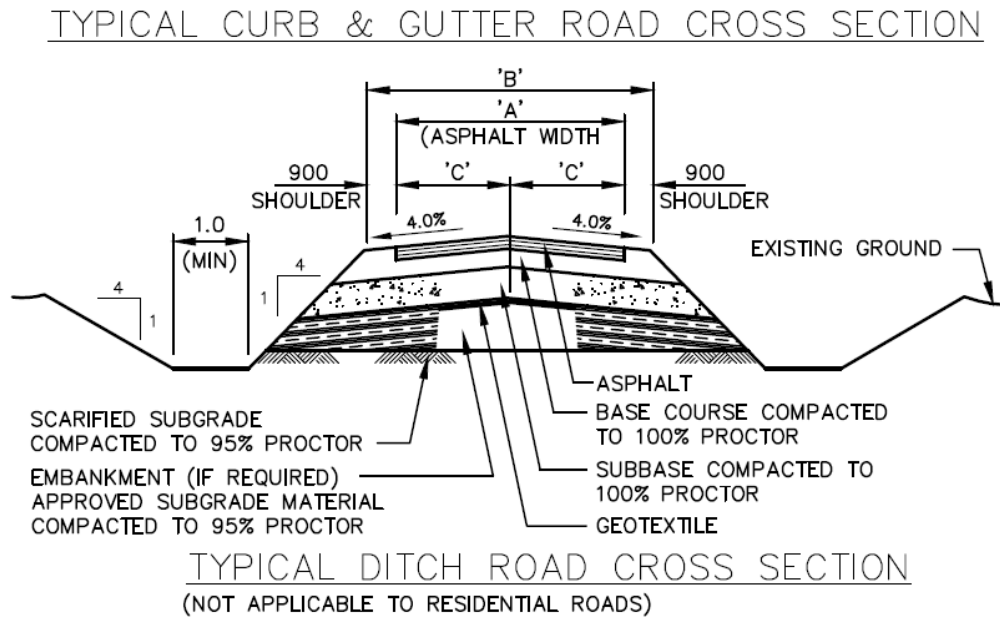
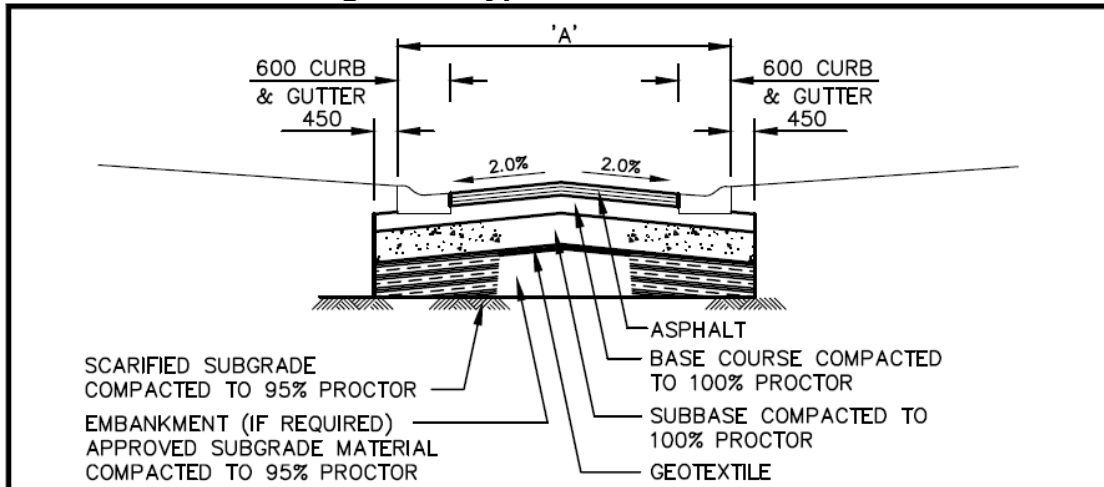

ROAD CLASSIFICATION	METRES			MILLIMETRES		
	'A'	'B'	'C'	ASPHALT THICKNESS (IF REQ'D)	BASE THICKNESS	SUBBASE THICKNESS
RESIDENTIAL	8.23	N/A	N/A	100	150	300
COLLECTOR	10.06	11.86	5.03	100	150	400
COMMERCIAL						
– LIGHT DUTY	8.23	10.03	4.115	100	200	400
– HEAVY DUTY	10.06	11.86	5.03	100	300	450

<p style="font-size: small; margin: 0;">1600 BUFFALO PLACE WINNIPEG, MANITOBA CANADA R3T 6B8 PHONE: 204-477-6650 FAX : 204-474-2864 WWW.WSP.COM</p>	PROJECT:	SUPPLEMENTAL:	
	TOWN OF NIVERVILLE SERVICING STANDARDS		ADDENDUM: <input type="checkbox"/> ADD_#
	TITLE: TYPICAL ROAD CROSS SECTION		DIRECTIVE: <input type="checkbox"/> DIR_#
			CHANGE ORDER: <input type="checkbox"/> CHG_#
		REVISION: REV_#	
DRAWN BY: A.L.M.		SCALE: N.T.S.	
CHECKED BY: M.P.M.		DATE: 2019/02/27	
		SUPPLEMENTAL NO: G07	
		PROJECT NO: 191-00330-00	

## 6.6 Surface

The following specifications are provided as information. Unless otherwise stipulated in a development agreement, hard surface paving is normally part of development servicing.

### (a) Pavement

One quarter gallon per square yard (1.35 litres per square metre) of liquid asphalt MC-O prime coat shall be applied at a temperature of 90-155 degrees F (32-68 degrees C) to the compacted base course. A sufficient thickness of asphalt concrete (cement penetration 150/200), plant mixed and heated to 260-310 degrees F. (127-155 degrees C), shall be placed to permit a uniform minimum pavement thickness of 4 inches (100 mm) on all roads, (placed in two lifts) after compaction. Full depth of asphalt is to be placed at time of initial construction.

### (b) Curb and Gutter

All roadways shall be designed with concrete curb and gutter drainage (with storm sewers as required), unless otherwise permitted in writing by the Town's Designated Officer. Where curbs and gutters are stipulated, roadways shall have a rolled style curb and gutter, 3 inches (75 mm) high. The curb and gutter shall consist of a six inch (150 mm) wide rolled curb and a gutter 18 inches (450 mm) wide, for a total width of 24 inches (600 mm) from back of curb to front of gutter. Barrier curb shall not be installed unless specified by the Town. The curb and gutter shall be slip formed concrete, with the gutter being 6 inches thick (150 mm).

## 6.7 Driveways

A minimum 15 foot (4.8 m) radius shall be maintained at **commercial and multi-family residential** approaches onto the main thoroughfare. A minimum 2% grade shall be maintained from the property line to the gutter. **Driveway width is to adhere to the latest version of the Town of Niverville Zoning Bylaw requirements.** If concrete driveways abut concrete curb and gutter, the driveway shall be secured to the curb and gutter by drilling into the existing concrete and installing dowels. Dowels shall be **15M epoxy coated bars**, 2 feet (600 mm) long, and installed at 3 feet (900 mm) on centre. Where open ditches prevail, a crown with 2% crossfall shall be provided and a culvert shall be installed under the driveway. Culvert size shall be as calculated by the Engineer as necessary for ditch design flows, but shall not be less than stipulated in Section 4.1(a). Driveway side slopes to ditch bottoms shall be graded no steeper than 4:1. No driveway shall fall within 25 feet (7.5 m) (as measured edge to edge) of an intersection between roadways. Where hydrant locations are required between driveways the hydrant shall be placed at a maximum distance between them, otherwise hydrants shall fall a minimum of 10 feet (3.0 m) from a driveway.

A driveway site plan shall be provided to the Town as part of building permit process. The surface treatment for driveways shall be reinforced concrete on new construction unless otherwise approved by the CAO or Designated Officer in writing.

### 6.8 Cul-de-sac

Road Classification	Right-of-Way Requirements	Road Surface Requirement
Residential	113 feet (34.4 m) diameter	70 feet (21.3 m) diameter
Collector	113 feet (34.4 m) diameter	70 feet (21.3 m) diameter
Commercial	*160 feet (48.5 m) diameter	*125 feet (38.1 m) diameter

\* Unless otherwise indicated by Council

### 6.9 Gravel Road Grade

Maximum longitudinal road grade to be 5%, with a crown of 4%, unless approved in writing by the CAO or Designated Officer. Vertical curves are required if the difference in the algebraic sum between descending and ascending gradients is equal to or greater than 2%.

## 7.0 SIDEWALKS

### 7.1 Design

All roadway construction methods and materials shall conform to the City of Winnipeg Standard Construction methods, most recent edition, with and exceptions being specifically outlined herein.

Unless specified by Council, sidewalks shall be a minimum of 5 feet (1.5 m) wide. Sidewalks shall be concrete; however, asphalt or limestone may be used in Public Reserves if prior approval by the Town's Designated Officer is granted. Minimum crossfall shall be 2% toward the roadway. Any silty or otherwise unsuitable subgrade material shall be excavated and removed and replaced with a suitable compacted subbase. The compacted base course shall be no less than 6 inches (150 mm) thick and extend 6 inches (150 mm) wider than the finished sidewalk. Concrete shall be no less than 5.5 inches (140 mm) thick. Rebar must be used; 10M, 2 feet on center (600 mm) or if crossing an approach: 20M, 1.0 foot (300 mm) on center. Rebar must be chaired at 1 ½ inches (37.5 mm) or 2 inches (50 mm) prior to pouring. See Section 12.0 for concrete specs. A 1/5 inch (5 mm) wide, 1 ½ inch (35 mm) deep transverse joint shall be provided every 5 feet (1.5 m).

Where sidewalks abut roadways or driveways, dowels shall be drilled into the existing concrete to secure the new sidewalk. If driveways are constructed after sidewalk installation, the sidewalk shall be saw cut and removed at the driveway location, and the new driveway shall be secured to the sidewalk by drilling into the existing sidewalk and installing dowels. Dowels shall be epoxy coated **15M bars**, minimum 2 feet (600 mm) long and installed at a minimum of 2 feet (600 mm) on centre.

Where a sidewalk intersects a curb at a road, a curb depression shall be installed, with a minimum clear opening of 6 feet (1800 mm), or the width of the sidewalk, whichever is more. Curb tapers shall only begin outside of the 6 foot (1800 mm) clear opening, where required. A Detectable Warning Surface Tile shall be installed in accordance with the City of Winnipeg Standard Construction Specifications, Section CW 3326, latest edition.

When approved by Council, walking paths installed in Public Reserves shall consist of: 3 inches (75 mm) of asphalt over 6 inches (150 mm) of limestone base material. Base shall be 6 inches (150 mm) wider than the finished surface. For all sidewalks installed in Public Reserves, a separation / reinforcement geotextile fabric shall be placed below base materials and shall be a woven fabric. Geotextile fabric shall be as specified in Section 6.5.

Typical sidewalk cross sections are shown on **Drawing G08**.



# Drawing G08 – Typical Details – Lanes, Sidewalks, Concrete Swales

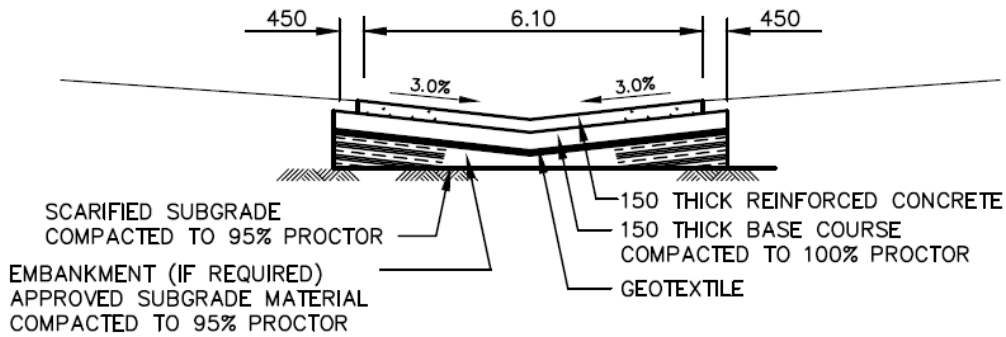

## TYPICAL RESIDENTIAL LANE CROSS SECTION

NOTE: CONCRETE LANES AND SIDEWALKS SHALL HAVE A BROOM FINISH

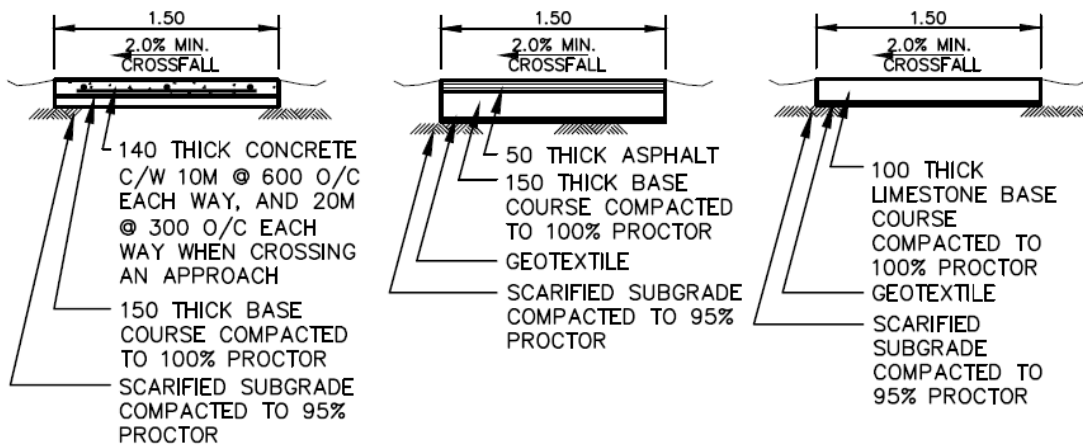

CONCRETE

ASPHALT

LIMESTONE BASE

## TYPICAL SIDEWALK CROSS SECTIONS

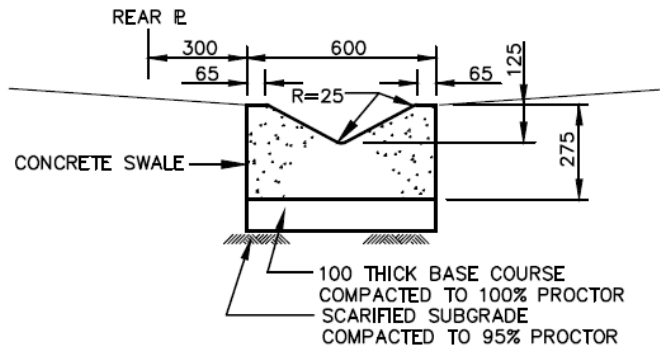

## TYPICAL CONCRETE SWALE CROSS SECTION

 <p>1600 BUFFALO PLACE WINNIPEG, MANITOBA CANADA R3T 6B8 PHONE: 204-477-6650 FAX : 204-474-2864 WWW.WSP.COM</p>	PROJECT:	TOWN OF NIVERVILLE SERVICING STANDARDS	SUPPLEMENTAL:	
	TITLE:	TYPICAL DETAILS – LANES, SIDEWALKS, CONCRETE SWALES	ADDENDUM: <input type="checkbox"/> ADD_# DIRECTIVE: <input type="checkbox"/> DIR_# CHANGE ORDER: <input type="checkbox"/> CHC_#	
	DRAWN BY:	A.L.M.	SCALE:	N.T.S.
	CHECKED BY:	M.P.M.	PROJECT NO:	191-00330-00
		DATE:	2019/02/27	
		REVISION:	REV_#	
		SUPPLEMENTAL NO:	G08	

STAMP

## **8.0 OTHER UTILITIES**

### **8.1 Hydro and Telephone**

Manitoba Hydro and Manitoba Telephone services shall be underground type for all urban developments. Street lighting shall be ornamental with LED type luminaires, located at a linear spacing no greater than 300 feet (90 m) with the provision that there shall be a street lighting unit at each roadway intersection and at each road bend more than 45 degrees.

Installation of all underground utilities (gas, hydro, telephone, cable) under proposed or existing roadways shall be by trenchless methods. No open cut excavation of roadways shall be permitted.

### **8.2 Road Signs**

All poles and signs shall be supplied and installed by the Town and billed back to developers to allow for consistency and quality control for signage throughout the Town.

## **9.0 BOULEVARD AND LOT GRADING**

### **9.1 Boulevards**

Boulevards shall be graded with positive slope from the front property line to the edge of road after utility and road construction (min. 2%, max 6% crossfall).

### **9.2 Lots**

Lots (meaning all properties beyond the road rights-of-way) shall be finish graded to comply with finish elevations, as per the approved grading plan prepared by the Developer's Consultant.

Lot areas not conforming to the rough graded criteria are allowed to permit the deposition of basement elevation within the stipulated lot. The Developer shall provide documentation itemizing rationale for any deviation from the rough graded criteria. Under no circumstances shall the lot be rough graded to permit the ponding of water within the residential lots. Final grading shall be the responsibility of the homeowner / house builder. Finish elevations shall ensure adequate drainage away from buildings toward drainage ditches, or gutters, as applicable. The house grades shall be designed such that there is relative uniformity within the development, for aesthetic purposes. Storm runoff from a property shall not be permitted to enter, or cross, an adjacent property or public property.

#### **9.2.1 Urban Lots**

Houses shall be "perched" with a minimum 6 inch (150 mm) berm around the foundation, and 2% min., 4% max. (unless otherwise approved by the Town for walk out basements), grade along the lot line to the gutter. All lot grading shall be sloped back to front, or split lot, where the back of the lot drains to either a road, lane or swale easement. Swale easements shall be a minimum of 10 feet (3.0 m) wide. Unless otherwise specified, swale easements shall incorporate a concrete swale, as indicated in **Drawings G08 and G09**.

## Drawing G09 – Lot Grading Criteria

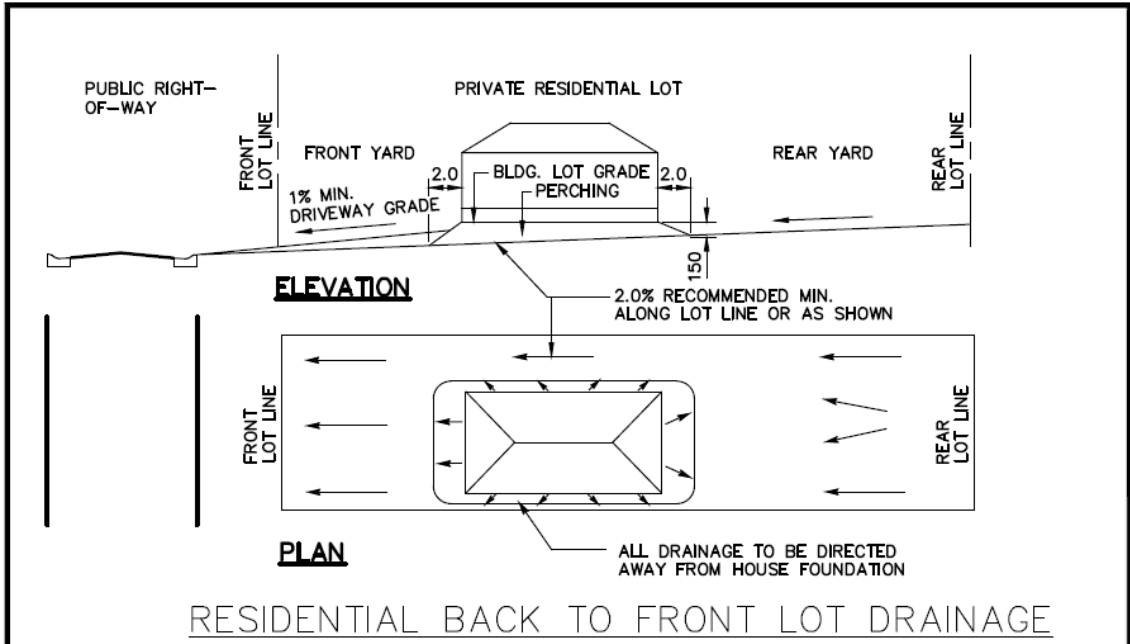

**NOTES:**

1. BUILDING TO BE SURROUNDED WITH "PERCHING".
2. BUILDING LOT GRADE TO BE FINISHED LANDSCAPE ADJACENT TO BUILDING.
3. PERCHING TO EXTEND BEYOND BUILDING AS FOLLOWS:  
 A) FRONT & REAR – 2.0 METRE (MIN.)  
 B) SIDE – 1.0 METRE (MIN.)
4. SIDE YARD SLOPE ALONG LOT LINE – 2.0% RECOMMENDED (MIN.)

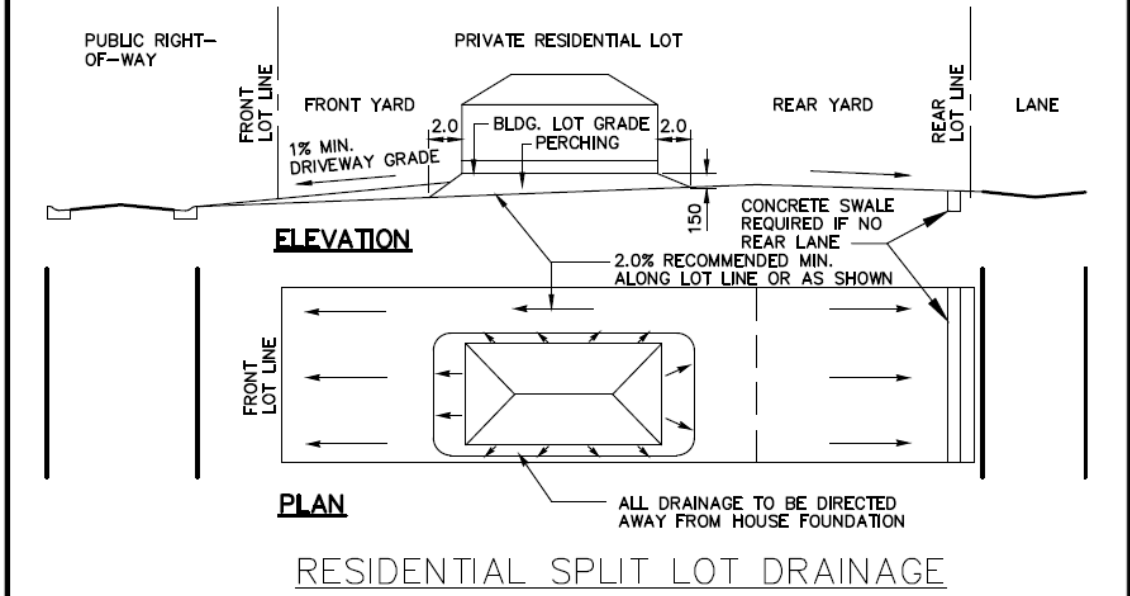

 1600 BUFFALO PLACE WINNIPEG, MANITOBA CANADA R3T 6B8 PHONE: 204-477-6650 FAX : 204-474-2864 WWW.WSP.COM	PROJECT: TOWN OF NIVERVILLE SERVICING STANDARDS		SUPPLEMENTAL:		
	TITLE: LOT GRADING CRITERIA		ADDENDUM: <input type="checkbox"/>	ADD_# <input type="checkbox"/>	
	DRAWN BY: A.L.M.		SCALE: N.T.S.	DIRECTIVE: <input type="checkbox"/>	DIR_# <input type="checkbox"/>
	CHECKED BY: M.P.M.		PROJECT NO: 191-00330-00	CHANGE ORDER: <input type="checkbox"/>	CHG_# <input type="checkbox"/>
			REVISION: <input type="checkbox"/>	REV_# <input type="checkbox"/>	
			DATE: 2019/02/27		
			SUPPLEMENTAL NO: G09		

## 10.0 PARKS

### 10.1 Greenspace / Public Reserve

#### 10.1.1 Urban Area Subdivisions

In new development areas or multi family infill projects, the Town requires either a land contribution equal to 10% of the total development area for green space, or alternatively the Town may accept a financial contribution equal to a 10% green space contribution.

Prior to the commencement of construction of each phase of the development, the designated area shall be approved by the Town. All designated greenspace areas shall be fully developed as per plans approved by the Town's Designated Officer.

#### 10.1.2 Public Reserves

Public reserves shall be cleared of all debris resulting from construction projects. No earth borrow pits shall be excavated on a public reserve without the written permission from the Town. No debris shall be buried on any public reserve, lot, or road right-of-way.

## 11.0 LANDSCAPING

### 11.1 General

The following applies to all developments subject to a Development Agreement and at the discretion of the Development Officer, and located in Commercial, Industrial, Community, Educational, Recreational and Residential Developments.

### 11.2 Requirements

A landscaping plan is required, and no landscaping work shall be commenced unless the landscaping plan is approved by the Development Officer.

### 11.3 Landscaping Plan

A landscaping plan shall contain the following information for the site:

- (a) All physical features, existing or proposed, including vegetation, berm contours, walls, fences, outdoor furniture and fixtures, surface utilities and paving;

- (b) All shrubs and trees, whether existing or proposed, labelled by their common name and size;
- (c) A site plan drawn to scale, including dimensions and distances, a north arrow and a clear legend;
- (d) All property lines with dimensions including adjacent sidewalks, curbs, driveway entrances, alleys, easements, and the location and name of adjacent streets;
- (e) Footprint for all existing and proposed structures including patios, and decks;
- (f) Building entrances, porches, decks, steps, walkways, parking areas, screens, fencing, lighting, and garbage collection areas;
- (g) Approximate location and type of adjacent land uses;
- (h) All surface utilities including fire hydrants, catch basins, utility covers;
- (i) The location of existing and proposed overhead and underground utilities;
- (j) Location, type and quantity of existing plant materials to be retained and what is to be removed;
- (k) All vegetation (trees, shrubs, grass areas) to be provided, including a plant list identifying type, size, and quantity of each and a calculation of the tree/shrub requirements;
- (l) The location and description of other landscape improvements such as earth berms, walls, fences, screens, sculptures, fountains, site furnishings, screened refuse containment areas and bicycle racks;
- (m) Existing and final site grading of the landscape areas;
- (n) Snow removal and storage sites; and
- (o) Other information as requested by the Development Officer.

#### **11.4 Landscaping Details**

- (a) Landscaping should be integrated with the building architectural style, parking and stormwater management areas proposed on the property.

- (b) Species must be hardy, drought- and salt-tolerant, and resistant to the stresses of compacted soils and weather exposure.
- (c) Snow storage areas must be located so that piled snow does not damage plant material.
- (d) Plant materials should not obstruct views. Dense plant material between 3 feet (0.91 m) and 8 feet (2.44 m) from the ground must be avoided in critical areas for pedestrian and vehicular safety. Plant materials cannot obstruct views to the street at access drives.
- (e) The applicant shall be responsible for landscaping and maintenance. Council may require landscaping be completed within two years after construction of the principal building or structure is completed. A letter of credit as insurance may be required to ensure landscaping is completed.
- (f) All side and rear yard site lines in the Industrial and Commercial zones which abut Residential or Parks and Open Space zones must be screened by a fence, hedge or evergreen trees which will extend a minimum of 6 feet (1.83 m) in height. Where chain link fencing is used, it shall be bordered by trees or hedges that, when planted, are expected to reach a height of not less than the height of the fence.

## **11.5 Parking**

- (a) Parking lot interior landscaping is required for all parking areas within Commercial, Institutional and Industrial Areas, that contain more than 30 automobile parking spaces.
- (b) 5% of the gross parking lot area must be landscaped;
- (c) One tree must be provided for each 300 square feet of parking lot interior landscape area and 1 shrub must be installed for each 100 square feet of parking lot interior landscape area;
- (d) Parking lot interior landscaping must be distributed within the parking area so as to break up the expanse of pavement.
- (e) Where landscaping is provided within landscaped parking islands, those islands must be a minimum of 5 feet wide; and
- (f) Required trees and shrubs may be clustered to create visual interest.

## 12.0 CONCRETE

Concrete shall conform to the following:

	<u>Curb &amp; Gutter, Bullnoses &amp; Lanes</u>	<u>Sidewalks, Medians &amp; Concrete Swales</u>
Compressive strength (28 day)	4640 psi (32 Mpa)	4350 psi (30 MPa)
Minimum cement content	575 lb/cu.ft. (335 kg/m <sup>3</sup> )	(same)
Maximum / water cement ratio	0.49:1	(same)
Maximum slump	3 - 1/6 in. (80 mm)	4 inch (100 mm)
Aggregate size (normal)	3/4 in. (20 mm)	(same)
Air content	5 - 7%	(same)
Cement type	CSA A5-M Type 10	(same)
Air entraining agent	CSA A266-1-M	(same)
Water reducing agent	CSA A266-2-M	(same)
Joint sealer	ASTM D1751	-
Reinforcing steel	CSA G30.12M	-
Reinforcing mat	Grade 40 bars	-
Curing compound	CGAB 90-GP-Ia	-



## 13.0 SEWAGE PUMPING STATIONS

### 13.1 Materials

(a) General

All materials shall conform to the relevant standard Approval Listings for the Manitoba Water Services Board.

(b) Barrels

Precast concrete barrels shall conform to ASTM C76 Class II with reinforced top and floor slabs.

(c) Miscellaneous Metal

Rungs shall be stainless steel, however PVC type shall be used for low pressure sewers (LPS). Frame and cover units shall be stainless steel.

(d) Pumps

Pumps shall be Flygt "C" or "N" type, or Barnes pumps. Where conventional gravity sewers are used, the impellers shall be capable of passing 3 inch (75 mm) solids, and the minimum acceptable motor power rating shall be 2.5 hp. "C" type pumps shall incorporate a minimum 3 inch (75 mm) through let. Three-phase pumps shall be used if power is available.

Pumps shall be complete with slide-away discharge elbows, guide rails and couplings. Barnes pumps shall incorporate a Flygt slide away system and discharge.

(e) Valves

Each pump shall have an HDL ball check valve mounted directly on the discharge elbow. For conventional gravity sewer lift stations, each pump shall have a stainless-steel knife gate valve mounted near the junction tee. For LPS systems, a plug valve shall be used in place of the knife gate.

A C509 resilient seat gate valve and box shall be provided on each incoming sewer line to permit shutting off flow into the station.

(f) Control System (SCADA)

The instrumentation and control system to be used in all new sewage pumping stations is the Flygt Multismart.

## 13.2 Design and Construction

(a) General

All design and construction shall conform generally to the standard specifications of the Manitoba Water Services Board. All lift stations require genset power backup to ensure continuity of services during power losses. Specification to be confirmed by Town appointed Engineer.

(b) Force mains

Bury depth, installation, and alignment shall conform generally to Section 2.2. Force mains may be installed in a common trench with sewer mains provided that a minimum 1 foot (0.3 m) clearance be maintained between pipes and between appurtenances.

(c) Design Criteria

Design flows shall be calculated as per the City of Winnipeg wastewater flow estimation and servicing guidelines. Provision shall be made in the structure and piping to permit installing larger pumps capable of increasing net output capacity by 50% without structural or mechanical alterations.

(d) Testing

The completed facility shall be tested by the design engineer for proper operation, correct impeller rotation, amperage draw and specific pumping output (drawdown test).

## **14.0 QUALITY ASSURANCE**

### **14.1 Installation**

All public works shall be installed to recognized engineering standards (City of Winnipeg, Manitoba Water Services Board, Manitoba Infrastructure and Transportation, AWWA, ASTM, etc.) and to the recommendations of the respective manufacturer or supplier of materials. All piping works shall be bedded, laid, joined, and back-filled to such standards and recommendations. All workmanship shall be first class and all materials shall be new and of best quality. Excavation permits shall be obtained, and all utilities shall be notified.

### **14.2 Testing**

Waterworks shall be flushed, disinfected and pressure tested for no less than two hours at 150 psi (1000 kPa), and leakage and pressure loss shall fall within allowable City of Winnipeg limits. All valves and hydrants shall be tested for proper operation. Gravity sewers shall be Mandrel Tested and closed-circuit television tested with a digital record of the testing being provided for review by the CAO or Designated Officer. Low pressure sewers shall be tested as above, to 75 psi (525 kPa). All water used for aforementioned operations shall be metered and purchased from the Town. Pressure testing shall incorporate a certified recording chart system. **All flushing operations shall be completed by the Town or under the Town's supervision.**

The roadway subgrade adequacy, sub-base and base course thickness and density, asphalt thickness and quality, and concrete shall be checked and tested by the design Engineer or testing laboratory, as applicable.

To ensure quality, there shall be on the site, throughout the construction, the registered professional engineer who was responsible for the design, or an authorized representative of that engineer.

The Engineer responsible for the design of the project shall certify at completion that all work has been done in conformance with the specifications, that all necessary tests have been done and that the results are adequate. Certification and copies of all relevant documentation (i.e. test results, video reviews, weekly site reports, etc.) shall be provided to the Town in electronic format on a USB stick.

### **14.3 Restoration and Clean-up**

All existing works and properties affected by construction shall be restored to the condition in which they existed prior to commencement of construction. All areas affected by construction shall be cleaned up and all excess or unused material shall be hauled away.

#### **14.4 Topsoil and Seeding**

Topsoil and seeding as required for new construction and/or project restoration shall be incidental to the work. Topsoil shall be placed and rolled to finished grade resulting in a 4 inch (100 mm) thick topsoil layer. Seeding shall follow City of Winnipeg Standard CW3520 for seeding.

## **15.0 PLANS**

### **15.1 Preliminary Documents**

The Developer shall supply a plan(s) completed by a professional engineer. Such plans shall indicate:

- All plans shall be prepared in electronic format using AutoCAD software, or approved equal, and submitted in hard copy, electronic PDF and in AutoCAD .dwg format.
- Proposed road and drainage grades, grade direction and elevations.
- Proposed water, wastewater, and land drainage sewer plans indicating pipe sizes, grades, direction of flow, hydrants, valves, and elevations.
- Proposed landscaping plans.
- Where the subdivision drainage may affect other properties outside the subdivision a drainage impact study completed by a professional engineer shall be required.
- Culvert sizes for roads and approaches.
- All drainage ditches or swales must be within the road allowances or on registered easements.
- Developer must obtain applicable approvals from all regulatory agencies for all construction (i.e. water rights licence for drainage, etc.).
- Existing topography of area.

### **15.2 As-Constructed Plans**

Within ninety (90) days of substantial completion of construction, the Engineer responsible for the design of the project shall take such measurements and surveys as necessary to provide complete detailed record drawings; and shall prepare "Record Drawing" plans to show the actual layout of all constructed works. The Town requires that the Engineer responsible for the design of the project validates design throughout the Construction phase with on-site resident inspections. Should a contractor fail to meet design specifications, the Engineer (and/or person designated by Town in writing at start of project) and Contractor must notify the Town within twenty-four (24) hours. Such plans will indicate the type of materials incorporated in the works. All record drawing plans shall be submitted in hard copy (2 full size copies) as well as electronic PDF and AutoCAD .dwg files on a USB drive.

### **15.3 Warranty Period**

All Public Works, both above and below ground shall be warranted by the Contractor against defects in products incorporated in the Works and against defects in execution for a period of one year, extending from the date of total performance of the Work as certified by the design engineer with the consent of

the CAO or Designated Officer. The CAO or Designated Officer shall be the sole judge as to the nature and cause of any defect and shall stipulate appropriate means by which the Contractor or design engineer must remedy any defect.

Once the roads and underground infrastructure is installed, the Developer's Engineer is responsible to arrange for a walk through with the Contractor, the CAO and/or Designated Officer(s) and the Developer. This is required prior to the CAO and/or Designated Officer(s) approving total performance of the project. During the walkthrough if the Developer's Engineer, or the CAO and/or Designated Officer(s) find deficiencies, they will be pointed out to the contractor on site. The Developer's Engineer will then create a deficiency list which will be emailed out to all parties for review. Once the deficiencies have been corrected, inspected by Town Staff, and signed off on by the CAO and/or Designated Officer, total performance is granted and the 1 (one) year warranty period begins. 40 (Forty) days prior to the end of the warranty period, a second walkthrough shall be organized by the Developer's Engineer with the Contractor, the CAO and/or Designated Officer(s), and the Developer. All walkthroughs must be completed between May 1st and October 31st in snow free conditions to allow visual inspections to be completed. If any additional deficiencies are identified by the CAO or Designated Officer during the warranty period they must be corrected prior to the Town signing off and taking full ownership of the infrastructure.